

# M

# ETAL GASKET SEAL FITTING

Clamp type



NTF

Nut type



VTF

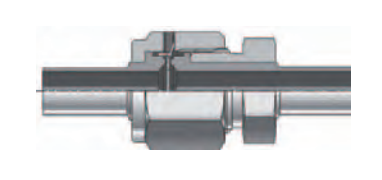
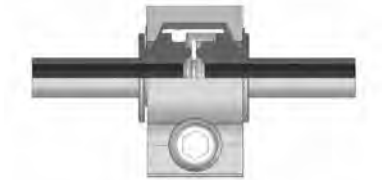

# Clamp Type Metal Gasket Seal Fitting NTF Series

Developed new concept of Metal Gasket Seal Fitting (NTF) that realized Particle free.

<Standard Assembly>

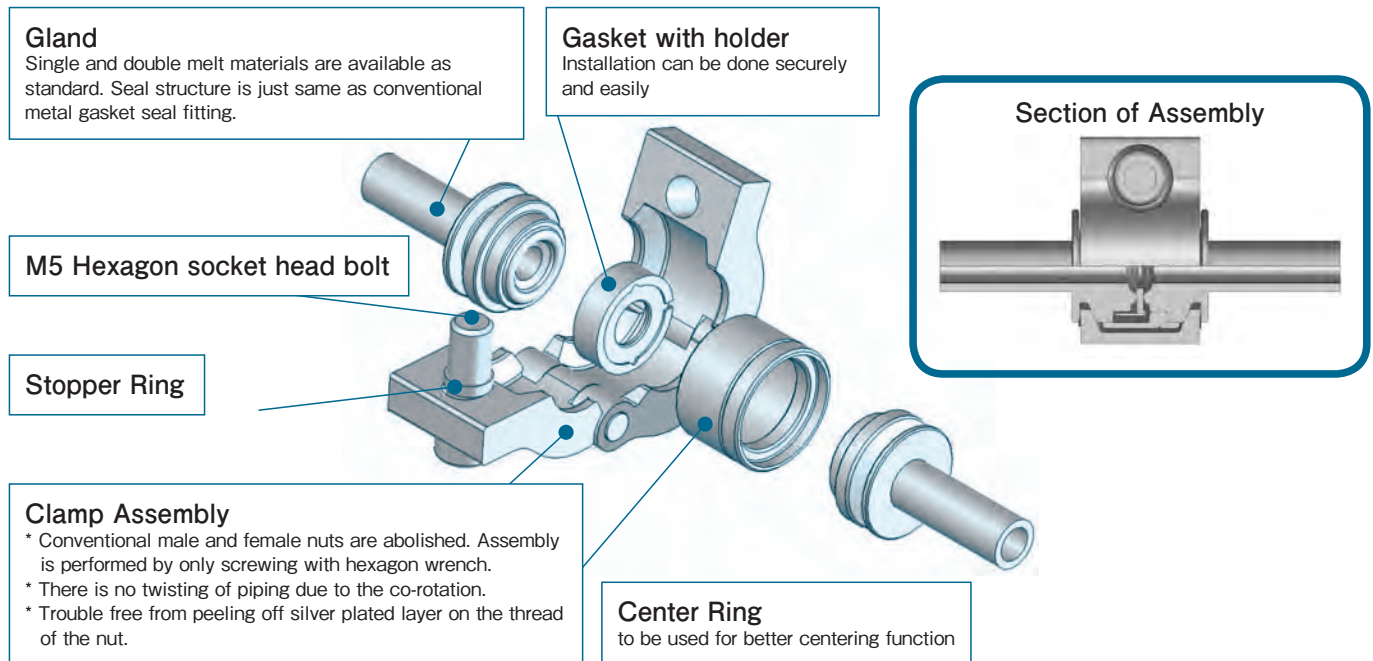

## ◆Features

The weak point of conventional metal gasket seal fitting are " Twisting of the piping and contamination of inside piping due to the generation of particles during nut tightening. NTF fitting is innovative clamp type metal gasket fitting that solved nut troubles.

- Through tightening a screw, it can generate same tightening force as a conventional.  
(Design and handle with care as NTF is inferior to the conventional against the abnormal force from outside)
- NTF fitting is suitable for the integration as the assembly work can be completed within a narrow space.
- Sealing is an exactly same structure as the conventional in the shape and dimension.
- NTF fitting is Rohs compliant product.

## ◆Specifications

Material used

Parts Name	Material
Gland Plug	SUS316L
Center Ring	SUS316
Clamp Assembly	SUS630
Gasket / Holder	Ni, SUS316LW double melted / SUS316

Working Pressure

Negative	VAC ~ 0 Pa
Positive	0 ~ 1 MPa

Range of Working Temperature

Range of Working Temperature	-60°C ~ 250°C
------------------------------	---------------

## ◆Assembly Procedure

1. Mount Gasket with holder on the left hand Gland in the above figure.
2. Insert the left hand gland into the Center ring (side of no identification groove)
3. Insert the other side gland into the Center ring and confront with both gland faces carefully so that do not damage the gasket.
4. In case of using torque wrench  
Cover the NTF Clamp assembly and tighten the screw up to 3 N · m torque.  
Secure if the clamp is correctly assembled (bending or diagonal setting of the clamp are prohibited).
5. In case of using hex-wrench  
Cover the NTF Clamp assembly and tighten the screw up to the stopper ring touch the clamp.  
As the excess tightening might damage the clamp, stop tightening when the stopper ring touch the clamp. ( Be careful of the excess tightening, as the hex-wrench tightening may exceed a little more than a torque wrench.)

# ◆ Nomenclature

NTF4-GE--07W

Fitting Type

Size at short pipe

display shape

Only when double melt material is used, W appears here.

Indication	Size
4	1/4"
6	3/8"

Grade of Internal finishing

Indication	Roughness $\mu\text{m}$	SS Tube Grade
32	Ra 0.8	BA
07	Ra 0.18	EP

Length

Blank: Standard length is 25.4 mm  
Any other length available as option

## ◆ Clamp type Metal Gasket Seal Fitting (NTF Fitting) Visual Index

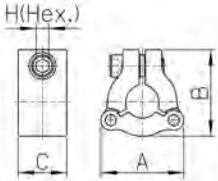
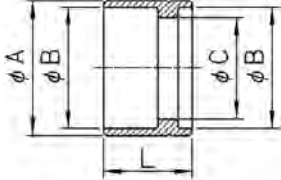
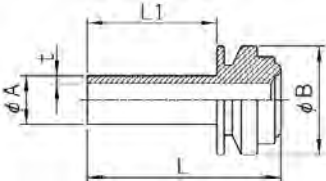
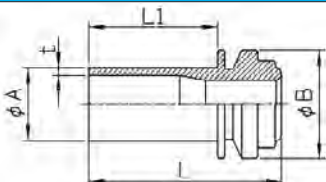
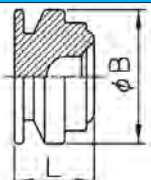
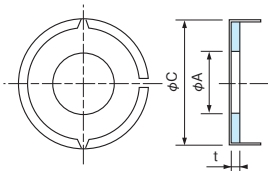
Clamp Assembly	Part No	A	B	C	H		
	NTF4-CLP	26.2	27.3	15.3	4.0		
Center Ring	Part No	L	$\phi A$	$\phi B$	$\phi C$		
	NTF4-CR	10.0	15.6	14.2	11.4		
Gland with collar	Part No	Size of NTF	Tube size ( $\phi A$ ) Thickness (t)		$\phi B$	L	L1
	NTF4-GE-※	1/4	6.35	1.0	14.2	25.4	17.0
High flow gland with collar	Part No	Size of NTF	Tube size ( $\phi A$ ) Thickness (t)		$\phi B$	L	L1
	NTF6-GE-※	1/4	9.53	1.0	14.2	25.4	17.0
Plug	Part No	Size of NTF	$\phi B$	L			
	NTF4-BL-※	1/4	14.2	8.4			
Gasket with holder	Part No	$\phi A$	$\phi C$	t			
	VTGR4 W	5.6	11.7	0.8			
	VTGR4 Ni	5.6	11.7	0.8			

※ Indicate the grade in the end

# NUT TYPE METAL GASKET SEAL FITTINGS : VTF SERIES

Ihara Technology can be found in every single fitting in our fluid conveyance system! We bring you VTF products that are reliable and easy to use.

< Standard Assembly >

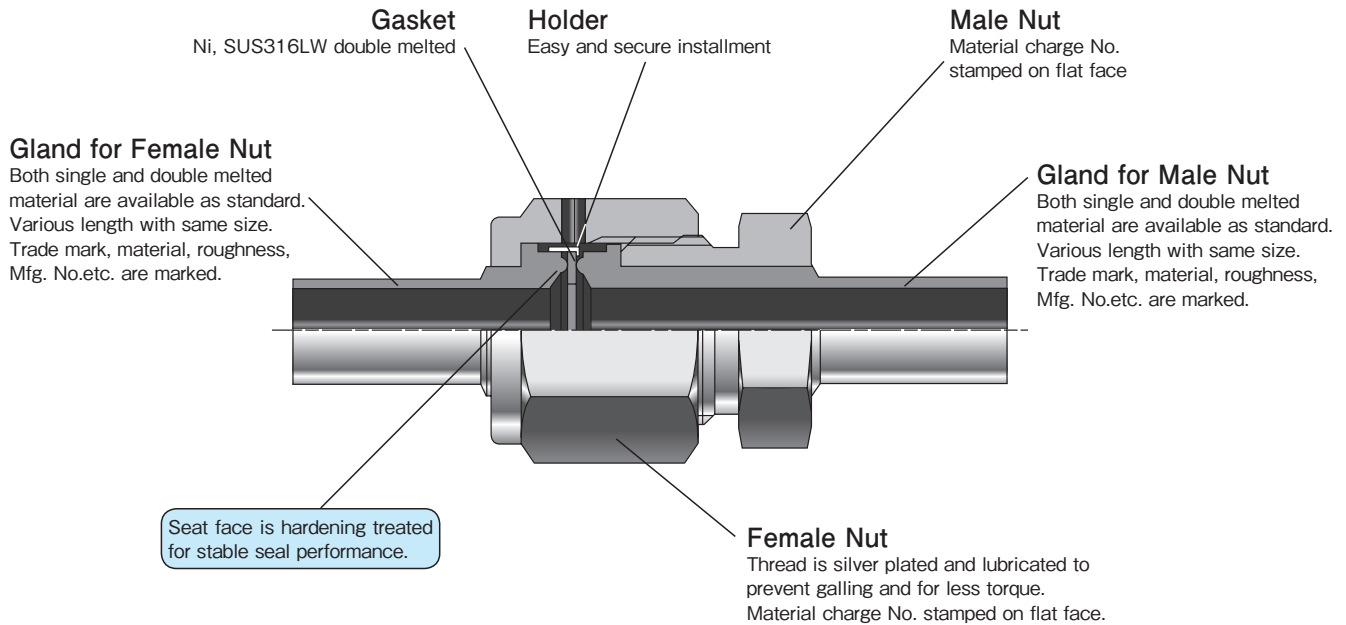

## ◆Features

1. Wide range applications from ultra high vacuum to high pressure, lower and higher temperature through metal gasket seal.
2. Spacing when install and uninstal can be minimized.
3. As the nut thread is silver plated and lubricated, tightening torque is reduced and also free from galling.
4. Thrust washer (VSTW) and thrust bearing (VTJR) are available for the protection from co-rotation of the tube when tightening female nut.
5. Material of the parts to be welded is SUS316 and is machined highly accurate.
6. For customers demanding high purity and ultra-high performance fittings, we offer products that come standard with W melt (VIM+VAR) materials, double melt material with almost no non-metallic inclusion and very low impurities such as Mn.
7. After the precision cleaning, protect seal surface of the fitting and vacuum packed one by one inside clean room.
8. Identification label showing product type, part symbol, inner roughness etc. is put on each product package.

## ◆Specification of Fitting

### Material used

Part No	Material
Gland Tube butt weld Connector Tube butt weld Elbow Tube butt weld Tee	SUS316L Single melt material Double melt material
Connector, Union Coupling, Adapter Elbow, Tee, Cross Nut, Plug	SUS316
Gasket / Holder	Ni, SUS316LW double melted / SUS316
Thrust Washer	Metal mesh+Fluorine resin
Thrust Bearing	SUS304 · SUS440C

### Working Pressure

Vacuum	VAC ~ 0 Pa
Positive	0 ~ 20.6 Mpa

\* As the temperature rises, allowable service pressure may decrease.

### Working Temperature Range

Gland, etc.	- 269 ~ 450°C
Connector, etc.	- 253 ~ 450°C
Gasket Ni	- 196 ~ 315°C
Gasket SUS316L	- 269 ~ 450°C
Thrust Washer	- 196 ~ 180°C
Thrust Bearing	- 196 ~ 350°C

## ◆ Nomenclature

**VTF-GD 8-4-43A-07W**

Weld display  
 W: for only welded parts

Type

Shape

**Size**

Symbol	Size	Symbol	Size
2	1/8"	8	1/2"
4	1/4"	12	3/4"
6	3/8"	16	1"

\*Gland size of gasket side is indicated first, then tube side follows.

**Internal Roughness**

Symbol	Internal Roughness	Stainless Tube
32	Ra 0.8	Equir. to BA tube
07	Ra 0.18	Equir. to EP tube
04*	Ra 0.1	Equiv.

\*Option

**Length**  
 \*For only A, B, C Type.

**Double Melt**  
 \* When double melt material is used, display "W" here.

## ◆ Types

To ensure that our customers are satisfied with the applications and cost performance of our products, we also offer the three types beyond our standard combination.

### ① Thrust bearing inserted type

Smooth tightening keeps tightening torque low for the female nut. Useful for preventing co-rotation with the gland, and minimal twisting during piping work.

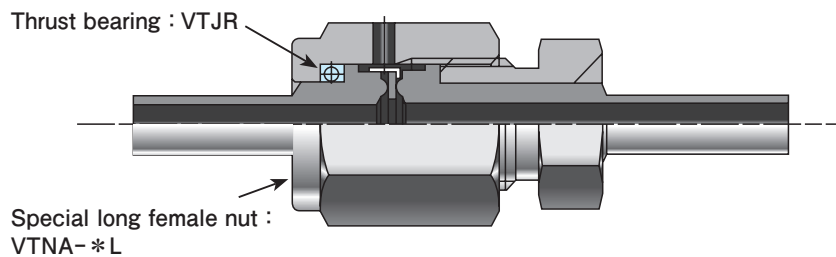

### ② Compact (High flow) type

Very compact, but realized high flow.

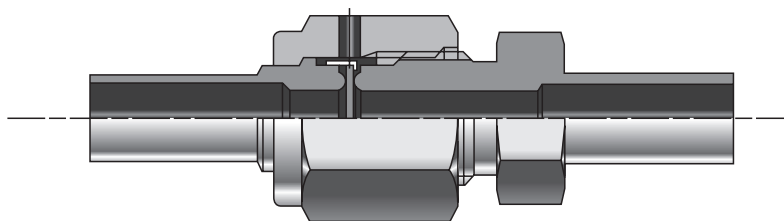





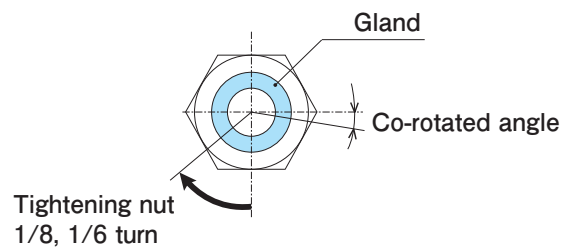

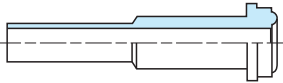

\* Reference: Data of gland co-rotation (in-house test data)

	Standard	Thrust washer/bearing inserted
	Tightened 1/8 turn	Tightened 1/6 turn
1/4"	2° ~ 2°30'	0°18' ~ 0°30'
1/2"	2°30' ~ 3°	0°30' ~ 1°

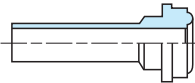
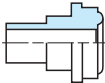

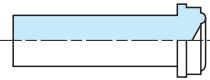
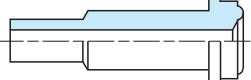
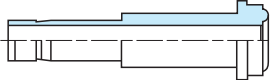
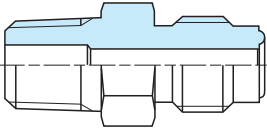
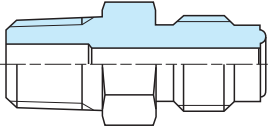
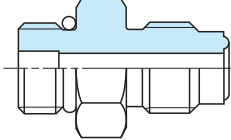
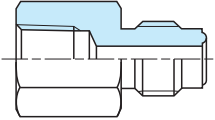
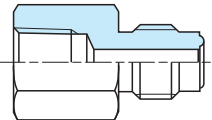
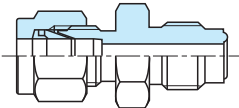
Any type of customized products are available, for instance, with less fittings and less welding. Feel free to inquire your customized requirement.

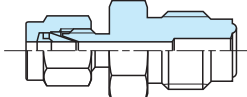
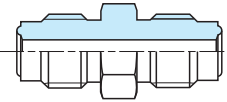
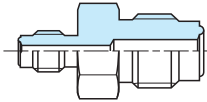

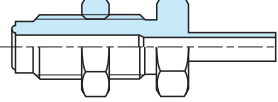
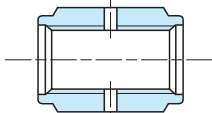
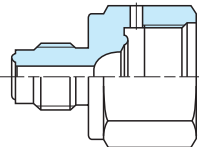
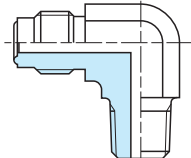
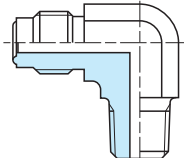
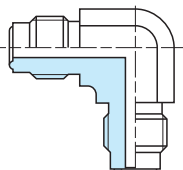
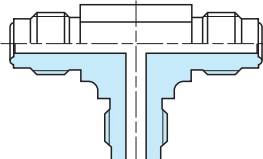
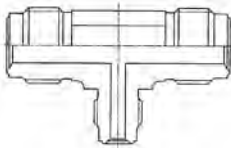
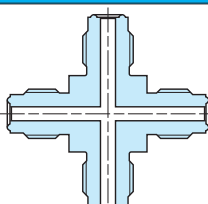
# VTF FITTINGS VISUAL INDEX

<p>Long Gland for Male Nut: VTGD, VTF-GD</p> 	<p>Short Gland for Male Nut: VTGM, VTGL</p> 	<p>Long Gland for Female Nut: VTGE, VTF-GE</p> 	<p>Short Gland for Female Nut: VTGN, VTGT</p> 
<p>Gland for Socket Weld: VTGC</p> 	<p>Blind Gland: VTF-*—BL</p> 	<p>Gland for Butt Weld: VTGB</p> 	<p>Gland for Tube Adapter: VTGAD</p> 
<p>Male Connector: VTCT (NPT thread)</p> 	<p>Male Connector: VTCT (R thread)</p> 	<p>Male Connector (Straight thread) : VTCU</p> 	<p>Female Connector: VTSA (NPT thread)</p> 
<p>Female Connector: VTSA (Rc thread)</p> 	<p>BI-LOK Fitting Connector: VTUB</p> 	<p>BI-LOK Bulkhead Fitting Connector: VTSB</p> 	<p>BI-LOK Fitting Bore Through Connector: VTUB *- BT</p> 
<p>Union: VTUA</p> 	<p>Reducing Union: VTUR</p> 	<p>Bulkhead Union: VTSU</p> 	<p>Bulkhead Connector for Tube Butt Weld: VTST</p> 
<p>Coupling: VTCG</p> 	<p>Reducing Adapter: VTSS</p> 	<p>Male Elbow: VTLN (NPT thread)</p> 	<p>Male Elbow: VTLN (R thread)</p> 
<p>Union Elbow: VTLA</p> 	<p>Union Tee: VTTA</p> 	<p>Reducing Tee</p> 	<p>Union Cross: VTXA</p> 

# VTF FITTINGS VISUAL INDEX

Connector for Resin tube fitting VTEP	Elbow for Butt Weld: VTLT	Tee for Butt Weld: VTTT	Tee for Butt Weld: VTKT
Tee for Butt Weld: VTNT			
<b>Welded Parts</b>	Welded Male Connector: WVTCT (R thread)	Welded Male Connector: WVTCT (R thread)	Welded Female Connector: WVTSA (Rc thread)
Welded Female Connector: WVTSA (Rc thread)	Welded BI-LOK Tube Fitting Connector: WVTUB	Closed Coupling: WVTGE	Reducing Closed Coupling: WVTRGE
Welded Female Elbow: WVTLA	Welded Female Tee: WVTTA	Welded Female Cross: WVTXA	Welded Male - Female Elbow: WVTLS
Welded Male - Female Tee: WVTTS	Welded Connector for resin tube fitting: WVTEP-M	Welded Elbow for resin tube fitting: WVTEP-L	
<b>NW Flange Welded Parts</b>	Female Nut Adapter with NW Flange Welded: VTF - NW *- * VF	Male Nut Adapter with NW Flange Welded: VTF - NW *- * VM	Tube - end Adapter with NW Flange Welded: VTF - NW *- * TW

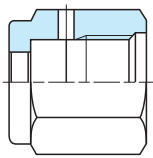
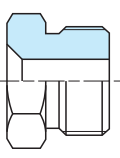
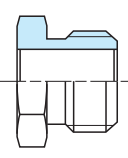
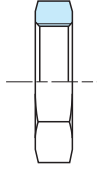
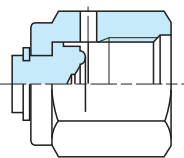
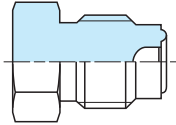
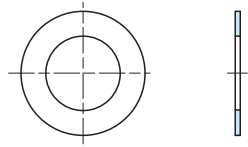
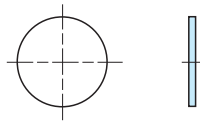
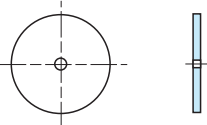
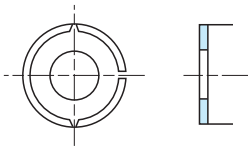
# VTF FITTINGS VISUAL INDEX

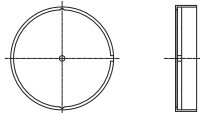
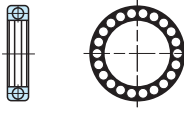
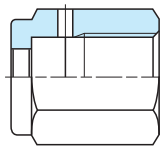
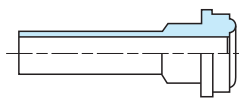
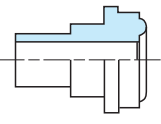
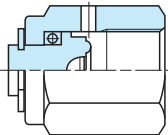
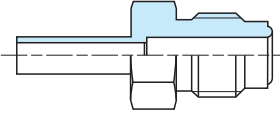
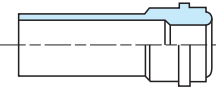
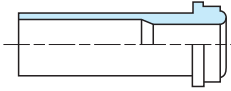
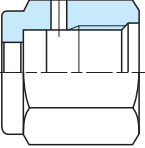
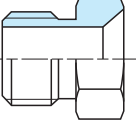
Female Nut: VTNA	Male Nut: VTNB	Short Male Nut: VTNB * S	Rock Nut: VTNN
			
Cap: VTCA	Plug: VTBA	Gasket: VTGP, VTGP * RN	Blind Gasket: VTBP
			
Orifice Gasket: VTOP	Gasket with Holder: VTGR	Blind Gasket with Holder VTBR	Orifice Gasket with Holder VTOR
			
<b>Thrust Bearing Inserted Type</b>	Thrust Bearing: VTJR	Female Nut for Thrust Bearing: VTNA -* L	Long Gland for Thrust Bearing Female Nut: VTF - GE -* L
			
Short Gland for Thrust Bearing Female Nut: VTF - GN -* L	Thrust Bearing Cap: VTCA * J		
			
<b>Compact (High Flow) Type</b>	Compact Coupling: VTGF	Gland for Compact Female Nut: VTGH, VTF - GH	Gland for Compact Male Nut: VTF - GK
			
Compact Female Nut: VTNC	Compact Male Nut: VTND		
			

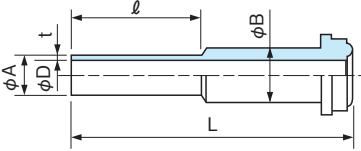
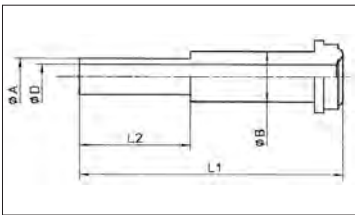

Long Gland for Male Nut	Part No	Size of VTF	Tube		$\phi D$	$\phi B$	L	$\ell$
			size ( $\phi A$ )	Thickness(t)				
 <p>with ● shows :</p> 	VTGD 2-2-※	1/8	3.18	0.72	1.74	5.1	17.8	7.1
	VTGD 4-2-※	1/4	3.18	0.72	1.74	8.8	33.3	10.4
	VTF-GD4-43A-※	1/4	6.35	1.0	4.35	8.8	43.2	19.05
	● VTF-GD4-43B-※	1/4	6.35	1.0	4.35	8.8	43.2	19.05
	VTF-GD4-43C-※	1/4	6.35	1.0	4.35	8.8	43.2	19.1
	VTGD 4-4-※	1/4	6.35	1.0	4.35	8.8	44.2	20.5
	VTF-GD8-4-46C-※	1/2 (3/8)	6.35	1.0	4.35	15.1	45.7	19.1
	VTGD 8-4-※	1/2 (3/8)	6.35	1.0	4.35	15.1	47.2	20.5
	VTF-GD8-6-45A-※	1/2 (3/8)	9.53	1.0	7.5	15.1	45.45	19.05
	● VTF-GD8-6-45B-※	1/2 (3/8)	9.53	1.0	7.5	15.1	45.5	19.05
	VTF-GD8-6-45C-※	1/2 (3/8)	9.53	1.0	7.5	15.1	45.5	19.1
	VTGD 8-6-※	1/2 (3/8)	9.53	1.0	7.5	15.1	47.2	20.5
	VTF-GD8-45A-※	1/2 (3/8)	12.7	1.24	10.2	15.1	45.45	19.05
	● VTF-GD8-45B-※	1/2 (3/8)	12.7	1.24	10.2	15.1	45.5	19.05
	VTF-GD8-45C-※	1/2 (3/8)	12.7	1.24	10.2	15.1	45.5	19.1
	VTGD 8-8-※	1/2 (3/8)	12.7	1.24	10.2	15.1	47.2	20.5
	VTGD 8-8T-※	1/2 (3/8)	12.7	1.0	10.7	15.1	47.2	20.5
	VTGD 12-4-※	3/4	6.35	1.0	4.35	22.2	52.0	20.5
	VTGD 12-6-※	3/4	9.53	1.0	7.5	22.2	52.0	20.5
	VTGD 12-8-※	3/4	12.7	1.24	10.2	22.2	52.0	20.5
	VTGD 12-12-※	3/4	19.05	1.65	15.75	22.2	52.0	20.5
	VTGD 12-12T-※	3/4	19.05	1.24	16.57	22.2	52.0	20.5
	VTF-GD12-52B-※	3/4	19.05	1.24	16.57	22.2	51.6	19.05
VTGD 16-16-※	1	25.4	1.65	22.1	30.2	58.9	19.05	

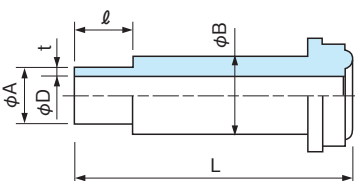
Short Gland for Male Nut	Part No	Size of VTF	Tube		$\phi D$	$\phi B$	L	$\ell$
			size ( $\phi A$ )	Thickness(t)				
	VTGM 4-4-※	1/4	6.35	1.0	4.35	8.8	30.5	6.35
	VTGL 4-4-※	1/4	6.35	1.0	4.35	8.8	31.8	7.0
	VTF-GM4-30C-※	1/4	6.35	1.0	4.35	8.8	30.5	6.4
	VTF-GM4-33A-※	1/4	6.35	1.0	4.35	8.8	33.5	6.35
	VTF-GM4-33C-※	1/4	6.35	1.0	4.35	8.8	33.5	9.7
	VTF-GM8-4-37A-※	1/2 (3/8)	6.35	1.0	4.35	15.1	37.5	6.35
	VTGM 8-6-※	1/2 (3/8)	9.53	1.0	7.5	15.1	32.8	6.35
	VTGL 8-6-※	1/2 (3/8)	9.53	1.0	7.5	15.1	34.7	7.0
	VTF-GM8-6-33C-※	1/2 (3/8)	9.53	1.0	7.5	15.1	32.8	6.4
	VTF-GM8-6-37A-※	1/2 (3/8)	9.53	1.0	7.5	15.1	37.5	6.35
	VTGM 8-8-※	1/2 (3/8)	12.7	1.24	10.2	15.1	32.8	6.35
	VTGL 8-8-※	1/2 (3/8)	12.7	1.24	10.2	15.1	34.7	7.5
	VTF-GM8-33C-※	1/2 (3/8)	12.7	1.24	10.2	15.1	32.8	6.4
	VTF-GM8-36C-※	1/2 (3/8)	12.7	1.24	10.2	15.1	35.8	9.7
	VTF-GM8-37A-※	1/2 (3/8)	12.7	1.24	10.2	15.1	37.5	6.35

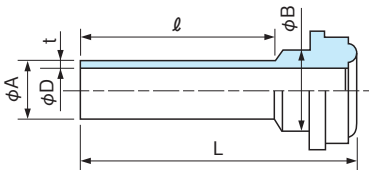
Long Gland for Female Nut	Part No	Size of VTF	Tube		$\phi D$	$\phi B$	L	$\ell$
			size ( $\phi A$ )	Thickness (t)				
	VTGE 2-2-※	1/8	3.18	0.72	1.74	5.1	12.2	7.1
	VTF-GE2-27B-※	1/8	3.18	0.72	1.74	5.1	27.4	19.05
	VTF-GE2-27C-※	1/8	3.18	0.72	1.74	5.1	27.4	19.1
	VTGE 4-2-※	1/4	3.18	0.72	1.74	8.8	28.5	7.1
	VTF-GE4-28A-※	1/4	6.35	1.0	4.35	8.8	28.0	19.05
	VTF-GE4-28B-※	1/4	6.35	1.0	4.35	8.8	27.9	19.05
	VTF-GE4-28C-※	1/4	6.35	1.0	4.35	8.8	27.9	19.1
	VTGE 4-4-※	1/4	6.35	1.0	4.35	8.8	29.0	20.5
	VTF-GE4-31A-※	1/4	6.35	1.0	4.35	8.8	31.0	19.05
	VTF-GE8-4-28B-※	1/2 (3/8)	6.35	1.0	4.35	15.1	28.5	19.05
	VTF-GE8-4-28C-※	1/2 (3/8)	6.35	1.0	4.35	15.1	28.4	19.1
	VTGE 8-4-※	1/2 (3/8)	6.35	1.0	4.35	15.1	31.6	20.5
	VTF-GE8-6-28B-※	1/2 (3/8)	9.53	1.0	7.5	15.1	28.5	19.05
	VTF-GE8-6-28C-※	1/2 (3/8)	9.53	1.0	7.5	15.1	28.4	19.1
	VTGE 8-6-※	1/2 (3/8)	9.53	1.0	7.5	15.1	30.0	20.5
	VTF-GE8-28B-※	1/2 (3/8)	12.7	1.24	10.2	15.1	28.5	19.05
	VTF-GE8-28C-※	1/2 (3/8)	12.7	1.24	10.2	15.1	28.4	19.1
	VTGE 8-8-※	1/2 (3/8)	12.7	1.24	10.2	15.1	30.0	20.5
	VTGE 8-8T-※	1/2 (3/8)	12.7	1.0	10.7	15.1	30.0	20.5
	VTGE 12-4-※	3/4	6.35	1.0	4.35	22.2	36.5	22.0
	VTGE 12-8-※	3/4	12.7	1.0	10.2	22.2	36.5	22.0
	VTGE 12-12-※	3/4	19.05	1.65	15.75	22.2	35.0	20.5
	VTGE 12-12T-※	3/4	19.05	1.24	16.57	22.2	35.0	20.5
	VTF-GE12-30B-※	3/4	19.05	1.24	16.57	22.2	30.5	19.05
VTGE 16-16-※	1	25.4	1.65	22.1	30.2	40.0	19.05	

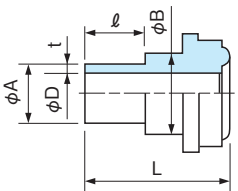
Short Gland for Female Nut	Part No	Size of VTF	Tube		$\phi D$	$\phi B$	L	$\ell$
			size ( $\phi A$ )	Thickness (t)				
	VTF-GN2-12B-※	1/8	3.18	0.72	1.74	?	12.2	7.0
	VTGT 4-2-※	1/4	3.18	0.72	1.74	8.8	18.0	7.0
	VTGN 4-4-※	1/4	6.35	1.0	4.35	8.8	15.2	6.35
	VTGT 4-4-※	1/4	6.35	1.0	4.35	8.8	18.0	7.0
	VTF-GN4-15C-※	1/4	6.35	1.0	4.35	8.8	15.2	6.4
	VTF-GN4-18A-※	1/4	6.35	1.0	4.35	8.8	18.2	6.35
	VTF-GN4-18C-※	1/4	6.35	1.0	4.35	8.8	18.3	9.7
	VTGN 8-4-※	1/2 (3/8)	6.35	1.0	4.35	15.1	15.2	6.35
	VTGT 8-4-※	1/2 (3/8)	6.35	1.0	4.35	15.1	20.1	7.0
	VTGN 8-6-※	1/2 (3/8)	9.53	1.0	7.5	15.1	15.2	6.35
	VTF-GN8-6-16C-※	1/2 (3/8)	9.53	1.0	7.5	15.1	15.7	6.4
	VTGT 8-6-※	1/2 (3/8)	9.53	1.0	7.5	15.1	20.1	7.0
	VTF-GN8-6-19A-※	1/2 (3/8)	9.53	1.0	7.5	15.1	19.3	6.35
	VTGN 8-8-※	1/2 (3/8)	12.7	1.24	10.2	15.1	15.2	6.35
	VTF-GN8-16C-※	1/2 (3/8)	12.7	1.24	10.2	15.1	15.7	6.4
	VTF-GN8-19C-※	1/2 (3/8)	12.7	1.24	10.2	15.1	18.8	9.7
	VTGT 8-8-※	1/2 (3/8)	12.7	1.24	10.2	15.1	20.1	7.5

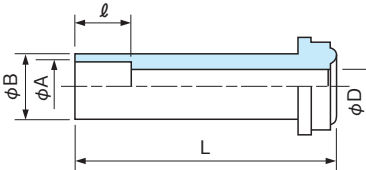
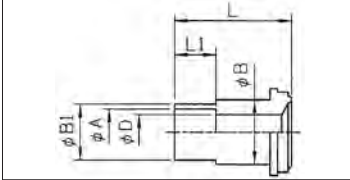
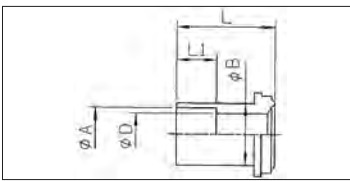
Gland for Socket Weld	Part No	Size of VTF	Tube	$\phi D$	$\phi B$	L	$\ell$
			size ( $\phi A$ )				
<b>VTGC,SVTGC(Short type)</b> < VTGC >  with ● shows :  < SVTGC > 	● VTGC 2-1-※	1/8	1.59	1.3	5.1	17.8	2.5
	VTGC 2-2-※	1/8	3.18	1.74	5.1	17.8	2.5
	VTGC 4-2-※	1/4	3.18	2.3	8.8	33.3	2.5
	VTGC 4-4-※	1/4	6.35	4.35	8.8	33.3	7.1
	VTGC 8-4-※	1/2 (3/8)	6.35	4.35	15.1	38.1	7.1
	VTGC 8-6-※	1/2 (3/8)	9.53	7.5	15.1	38.1	7.9
	VTGC 8-8-※	1/2 (3/8)	12.7	10.2	15.1	38.1	9.7
	VTGC 12-12-※	3/4	19.05	15.7	22.2	50.8	11.2
	VTGC 16-16-※	1	25.4	22.1	30.2	56.4	15.7
	SVTGC 4-4-※	1/4	6.35	4.35	8.8	19.1	7.1
	SVTGC 4-12C-※	1/4	6.35	4.35	8.8	12.7	7.1
	SVTGC 8-4-※	1/2 (3/8)	6.35	4.35	15.1	24.1	7.1
	SVTGC 8-6-※	1/2 (3/8)	9.53	7.5	15.1	24.1	7.9
	SVTGC 8-8-※	1/2 (3/8)	12.7	10.2	15.1	24.1	9.7

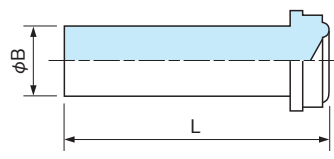
Blind G	Part No	Size of VTF	$\phi B$	L
<b>VTF-※-BL</b> 	VTF-GC2-BL-※	1/8	5.1	17.8
	VTF-GC4-BL-※	1/4	8.8	33.3
	VTF-GC8-BL-※	1/2 (3/8)	15.1	38.1
	VTF-GC12-BL-※	3/4	22.2	50.8
	VTF-GC16-BL-※	1	30.2	56.4

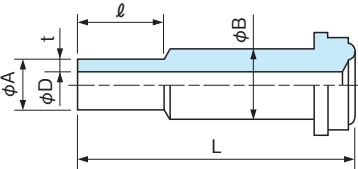
Gland for Butt Weld	Part No	Size of VTF	Tube		$\phi D$	$\phi B$	L	$\ell$
			size ( $\phi A$ )	Thickness(t)				
<b>VTGB,VTF-GB</b> 	VTGB 2-2-※	1/8	3.18	0.72	1.74	5.1	17.8	7.1
	VTGB 4-2-※	1/4	3.18	0.72	1.74	8.8	33.3	10.4
	VTF-GB4-2-33C-※	1/4	3.18	0.72	1.74	8.8	33.3	7.1
	VTGB 4-4-※	1/4	6.35	1.0	4.35	8.8	33.3	10.4
	VTF-GB4-33C-※	1/4	6.35	1.67	3.0	8.8	33.3	10.4
	VTGB 8-4-※	1/2 (3/8)	6.35	1.0	4.35	15.1	38.1	10.4
	VTF-GB8-4-38C-※	1/2 (3/8)	6.35	1.67	3.0	15.1	38.1	10.4
	VTGB 8-6-※	1/2 (3/8)	9.53	1.0	7.5	15.1	38.1	10.4
	VTF-GB8-6-38C-※	1/2 (3/8)	9.53	1.21	7.1	15.1	38.1	10.4
	VTF-GB8-38C-※	1/2 (3/8)	12.7	1.24	10.2	15.1	38.1	12.7
	VTGB 8-8-※	1/2 (3/8)	12.7	1.24	10.2	15.1	38.1	12.7
	VTGB 12-8-※	3/4	12.7	1.24	10.2	22.2	50.8	15.7
	VTGB 12-12-※	3/4	19.05	1.65	15.75	22.2	50.8	15.7
	VTGB 16-16-※	1	25.4	1.65	22.1	30.2	56.4	20.6

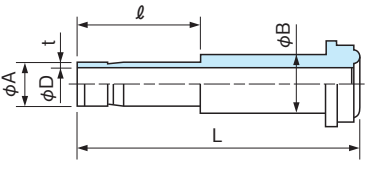
Gland for Tube Adapter	Part No	Size of VTF	Tube		$\phi D$	$\phi B$	L	$\ell$
			size ( $\phi A$ )	Thickness (t)				
	VTGAD 2-2-※	1/8	3.18	0.72	1.74	5.1	36.0	15.5
	VTGAD 4-4-※	1/4	6.35	1.0	4.35	8.8	41.0	16.2
	VTGAD 8-4-※	1/2 (3/8)	6.35	1.0	4.35	15.1	46.0	16.2
	VTGAD 8-6-※	1/2 (3/8)	9.53	1.36	6.8	15.1	46.0	17.8
	VTGAD 8-8-※	1/2 (3/8)	12.7	1.65	9.4	15.1	49.3	24.4
	VTGAD 12-8-※	3/4	12.7	1.65	9.4	22.2	57.2	24.4
	VTGAD 12-12-※	3/4	19.05	1.65	15.75	22.2	58.0	25.2

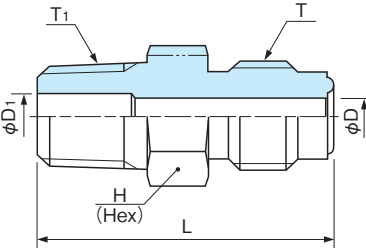
Male Connector (NPT thread)	Part No	Size of VTF	T <sub>1</sub> NPT thread	$\phi D$	$\phi D_1$	H Hex. size	L
	VTCT 2-1-※	1/8	1/16	2.3	2.3	9.53	26.2
	VTCT 2-2-※	1/8	1/8	2.3	4.4	11.11	26.2
	VTCT 4-2-※	1/4	1/8	4.35	4.35	15.88	32.5
	VTCT 4-4-※	1/4	1/4	4.35	6.0	15.88	37.8
	VTCT 4-6-※	1/4	3/8	4.35	7.5	19.05	38.0
	VTCT 8-4-※	1/2 (3/8)	1/4	10.2	6.0	23.81	41.0
	VTCT 8-6-※	1/2 (3/8)	3/8	10.2	9.7	23.81	41.1
	VTCT 8-8-※	1/2 (3/8)	1/2	10.2	10.2	23.81	46.0
	VTCT 8-12-※	1/2 (3/8)	3/4	10.2	15.75	33.34	47.8
	VTCT 8-16-※	1/2 (3/8)	1	10.2	22.1	34.93	55.8
	VTCT 12-4-※	3/4	1/4	15.75	6.0	33.34	48.7
	VTCT 12-6-※	3/4	3/8	15.75	9.7	33.34	48.8
	VTCT 12-8	3/4	1/2	15.75	10.2	33.34	53.8
	VTCT 12-12-※	3/4	3/4	15.75	15.75	33.34	53.8
	VTCT 16-16-※	1	1	22.1	22.1	41.28	62.6

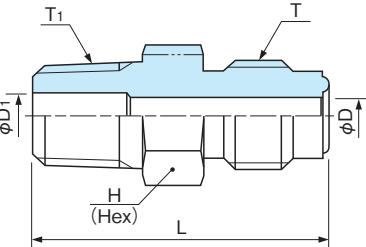
Male Connector (R thread)	Part No	Size of VTF	T <sub>1</sub> R thread	$\phi D$	$\phi D_1$	H Hex. size	L
	VTCT 2-R1-※	1/8	1/16	2.3	2.3	9.53	26.2
	VTCT 2-R2-※	1/8	1/8	2.3	4.4	11.11	26.2
	VTCT 4-R2-※	1/4	1/8	4.35	4.35	15.88	32.5
	VTCT 4-R4-※	1/4	1/4	4.35	6.0	15.88	37.8
	VTCT 4-R6-※	1/4	3/8	4.35	7.5	19.05	40.0
	VTCT 4-R8-※	1/4	1/2	4.35	10.2	23.81	43.7
	VTCT 8-R4-※	1/2 (3/8)	1/4	10.2	6.0	23.81	41.0
	VTCT 8-R6-※	1/2 (3/8)	3/8	10.2	9.7	23.81	42.1
	VTCT 8-R8-※	1/2 (3/8)	1/2	10.2	10.2	23.81	46.0
	VTCT 8-R12-※	1/2 (3/8)	3/4	10.2	15.75	33.34	47.8
	VTCT 8-R16-※	1/2 (3/8)	1	10.2	22.1	34.93	55.8
	VTCT 12-R4	3/4	1/4	15.75	6.0	33.34	48.7
	VTCT 12-R6	3/4	3/8	15.75	9.7	33.34	48.8
	VTCT 12-R8	3/4	1/2	15.75	10.2	33.34	53.8
	VTCT 12-R12-※	3/4	3/4	15.75	15.75	33.34	53.8?
VTCT 16-R16-※	1	1	22.1	22.1	41.28	62.6	

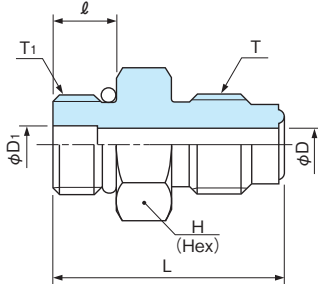
Male Connector (Straight thread)	Part No	Size of VTF	T <sub>1</sub> unified thread	φD	φD <sub>1</sub>	ℓ	H Hex. size	L	O-ring AS568
	VTCU 4-4-※	1/4	7/16-20	4.35	5.2	9.1	19	33.0	-904
	VTCU 4-6-※	1/4	9/16-18	4.35	7.1	9.9	19	33.8	-906
	VTCU 8-6-※	1/2 (3/8)	9/16-18	7.5	7.5	9.9	23.81	37.6	-906
	VTCU 8-8-※	1/2 (3/8)	3/4-16	10.2	10.2	11.1	23.81	38.8	-908
	VTCU 8-10-※	1/2 (3/8)	7/8-14	7.5	15.0	12.7	25.4	42.2	-910
	VTCU 12-6-※	3/4	9/16-18	15.75	7.1	9.9	33.34	45.1	-906
	VTCU 12-12-※	3/4	1-1/16-12	15.75	15.75	15.09	33.34	52.3	-912
* O-ring is standard accessory. (Material is FKM)									

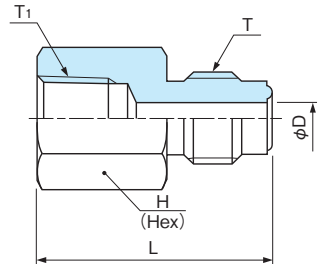
Female Connector (NPT thread)	Part No	Size of VTF	T <sub>1</sub> NPT thread	φD	H Hex. size	L
	VTSA 2-1-※	1/8	1/16	2.3	11.11	29.5
	VTSA 2-2-※	1/8	1/8	2.3	14.29	30.2
	VTSA 4-2-※	1/4	1/8	4.35	15.88	35.8
	VTSA 4-4-※	1/4	1/4	4.35	19	36.6
	VTSA 8-4-※	1/2 (3/8)	1/4	10.2	23.81	38.0
	VTSA 8-6-※	1/2 (3/8)	3/8	10.2	23.81	41.1
	VTSA 8-8-※	1/2 (3/8)	1/2	10.2	26.99	48.5
	VTSA 8-16-※	1/2 (3/8)	1	10.2	41.28	55
	VTSA 12-12-※	3/4	3/4	15.75	33.34	55.6
	VTSA 16-16-※	1	1	22.1	41.28	63.8

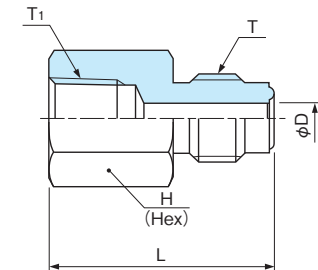
Female Connector (Rc thread)	Part No	Size of VTF	T <sub>1</sub> NPT thread	φD	H Hex. size	L
	VTSA 2-R1-※	1/8	1/16	2.3	11.11	29.5
	VTSA 2-R2-※	1/8	1/8	2.3	14.29	30.2
	VTSA 4-R2-※	1/4	1/8	4.35	15.88	35.8
	VTSA 4-R4-※	1/4	1/4	4.35	19	36.6
	VTSA 8-R4-※	1/2 (3/8)	1/4	10.2	23.81	38.0
	VTSA 8-R6-※	1/2 (3/8)	3/8	10.2	23.81	41.1
	VTSA 8-R8-※	1/2 (3/8)	1/2	10.2	26.99	48.5
	VTSA 12-R8-※	3/4	1/2	15.75	33.34	54.6
	VTSA 12-R12-※	3/4	3/4	15.75	33.34	55.6
	VTSA 16-R12-※	1	3/4	22.1	41.28	63.8
	VTSA 16-R16-※	1	1	22.1	41.28	63.8

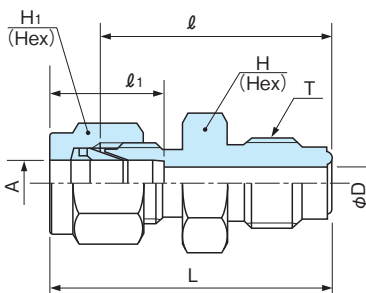
BI-LOK Fitting Connector	Part No	Size of VTF	Tube	$\phi D$	H Hex. size	H <sub>1</sub> Hex. size	$\ell_1$	L
			size ( $\phi A$ )					
	VTUB 2-2-※	1/8	3.18	2.3	15.88	11.11	13	37.9
	VTUB 4-2-※	1/4	3.18	4.35	15.88	11.11	13	38.6
	VTUB 4-4-※	1/4	6.35	4.35	15.88	14.29	15.4	40.7
	VTUB 4-8-※	1/4	12.7	4.35	23.81	22.23	23	46.3
	VTUB 8-4-※	1/2 (3/8)	6.35	7.5	23.81	14.29	15.4	45.5
	VTUB 8-6-※	1/2 (3/8)	9.53	7.5	23.81	17.46	17	46.3
	VTUB 8-8-※	1/2 (3/8)	12.7	10.2	23.81	22.23	23	49.6
	VTUB 8-12-※	1/2 (3/8)	19.05	10.2	26.99	28.58	24.6	55.3
	VTUB 12-8-※	3/4	12.7	15.75	33.34	22.23	23	57.4
	VTUB 12-12-※	3/4	19.05	15.75	33.34	28.58	24.6	57.4
	VTUB 12-16-※	3/4	25.4	15.75	38.1	38.1	31.6	62.6
	VTUB 16-4-※	1	6.35	22.1	41.27	14.29	15.4	56.5
	VTUB 4-6M-※	1/4	6.0	4.35	15.88	14	15.4	40.7

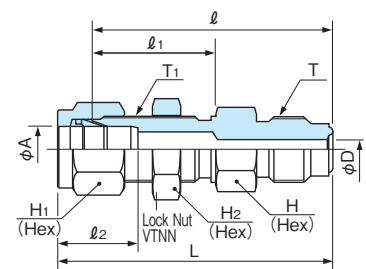
BI-LOK Bulkhead Fitting Connector	Part No	Size of VTF	Tube	$T_1$ unified thread	$\phi D$	H Hex. size	H <sub>1</sub> Hex. size	$\ell_2$	H <sub>2</sub> Hex. size	L
			size ( $\phi A$ )							
	VTSB 4-4-※	1/4	6.35	7/16-20	4.35	15.88	14.29	15.4	15.88	57.5
	VTSB 4-4S-※	1/4	6.35	7/16-20	4.35	15.88	14.29	15.4	15.88	48.1
	VTSB 4-6-※	1/4	9.53	9/16-20	4.35	19.00	17.46	17.0	19	58.3
	VTSB 8-6-※	1/2 (3/8)	9.53	9/16-20	7.5	23.81	17.46	17.0	19	64.9
	VTSB 8-8-※	1/2 (3/8)	12.7	3/4-20	10.2	23.81	22.23	23.0	23.81	70.0
	VTSB 8-12-※	1/2 (3/8)	19.05	1-20	10.2	30.16	28.58	24.6	30.16	87.1
	VTSB 12-12-※	3/4	19.05	1-20	15.75	33.34	28.58	24.6	30.16	93.3
	VTSB 16-16-※	1	25.4	1-5/16-20	22.1	41.28	38.1	31.6	41.28	96.3

Lock Nut : VTNN Refer to P.22

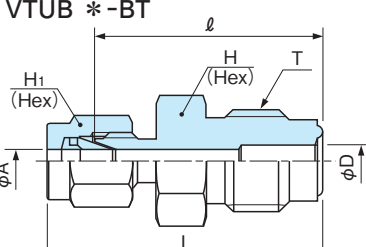
BI-LOK Fitting Bore Through Connector	Part No	Size of VTF	Tube	$\phi D$	H Hex. size	H <sub>1</sub> Hex. size	L
			size ( $\phi A$ )				
	VTUB 4-1-BT-※	1/4	1.58	4.35	15.88	7.93	34.12
	VTUB 4-2-BT-※	1/4	3.17	4.35	15.88	11.11	38.45
	VTUB 8-8M-BT-※	1/2 (3/8)	8	10.2	23.81	17.0	46.0

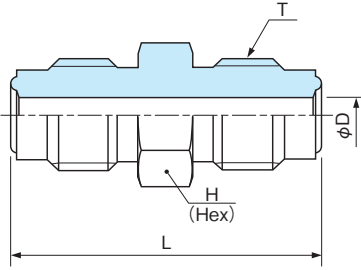
Union	Part No	Size of VTF	$\phi D$	H Hex. size	L
	VTUA 2-※	1/8	2.3	9.53	27.7
	VTUA 4-※	1/4	4.35	15.88	38.9
	VTUA 8-※	1/2 (3/8)	10.2	23.81	46.0
	VTUA 12-※	3/4	15.75	33.34	60.5
	VTUA 16-※	1	22.1	41.27	64.6
	VTF-UA2-※	1/8	2.3	9.53	28.7
	VTF-UA4-※	1/4	4.35	15.88	39.4
	VTF-UA8-※	1/2 (3/8)	10.2	23.81	46.7

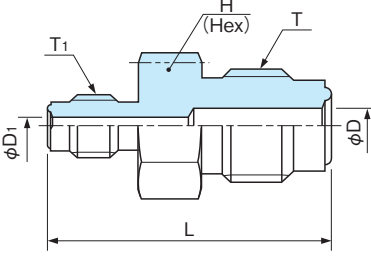
Reduced Union	Part No	Size of VTF	Size of VTF	$\phi D$	$\phi D_1$	H Hex. size	L
	VTUR 4-2-※	1/4	1/8	4.35	2.3	15.88	35.1
	VTUR 8-4-※	1/2 (3/8)	1/4	7.5	4.35	23.81	43.4
	VTUR 12-4-※	3/4	1/4	15.75	4.35	33.34	51.0
	VTUR 12-8-※	3/4	1/2	15.75	10.2	33.34	55.0
	VTUR 16-4-※	1	1/4	22.1	4.35	41.28	55.0
	VTUR 16-8-※	1	1/2	22.1	10.2	41.28	58.0
	VTUR 16-12-※	1	3/4	22.1	15.75	41.28	65.0

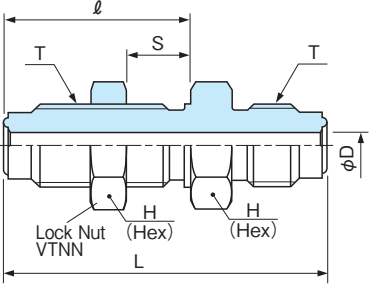
Bulkhead Union	Part No	Size of VTF	T unified thread	$\phi D$	$\ell$	S Max	H Hex. size	L	Diameter of wall through hole
	VTSU 2-※	1/8	5/16-24	2.3	23.5	6	11.11	41.0	9.0
	VTSU 4-※	1/4	9/16-18	4.35	31.8	11.2	19	54.9	15.0
	VTSU 8-※	1/2 (3/8)	7/8-14	10.2	36.6	12.7	26.99	63.5	23.0
	VTSU 12-※	3/4	1 1/4-18	15.75	46.6	17.46	38.1	82.0	32.5
	VTSU 16-※	1	1 1/2-20	22.1	50.0	17.46	47.63	88.5	39.0
	VTF-SU4-※	1/4	9/16-18	4.35	33.0	11.2	19	56.6	15.0
	VTF-SU4S-※	1/4	9/16-18	4.35	25.1	3.3	19	46.2	15.0
	VTF-SU8-※	1/2 (3/8)	7/8-14	10.2	37.6	12.7	26.99	65.3	23.0
	VTF-SU8S-※	1/2 (3/8)	7/8-14	10.2	28.2	3.3	26.99	54.4	23.0

Lock Nut : VTNN Refer to P.22

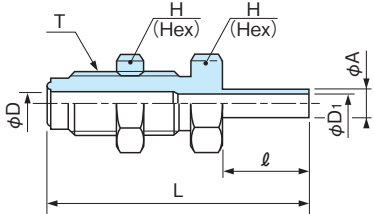
Bulkhead Connector for Tube Butt Weld	Part No	Size of VTF	T unified thread	$\phi D$	$\phi A$	$\phi D_1$	$\ell$	H Hex. size	L	Diameter of wall through hole
	VTST 4-4-※	1/4	9/16-18	4.35	6.35	4.35	19.1	19	59.9	15.0
	VTST 6-6-※	1/2 (3/8)	7/8-14	7.5	9.53	7.5	19.1	26.99	63.3	23.0
	VTST 8-6-※	1/2 (3/8)	7/8-14	10.2	9.53	7.5	19.1	26.99	63.3	23.0
	VTST 8-8-※	1/2 (3/8)	7/8-14	10.2	12.7	10.2	19.1	26.99	63.3	23.0
	VTST 12-12-※	3/4	1-1/4-18	16.8	19.05	15.75	19.1	38.1	75.8	32.5
	VTF-ST4-4S-※	1/4	9/16-18	4.8	6.35	4.35	19.1	19.05	49.5	15.0

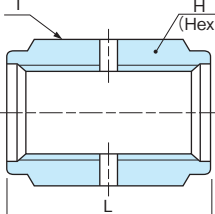
Coupling	Part No	Size of VTF	H Hex. size	L
	VTCG 2-※	1/8	11.11	16.8
	VTCG 4-※	1/4	19	30.2
	VTCG 8-※	1/2 (3/8)	26.99	33.3
	VTCG 12-※	3/4	38.1	42.7
	VTCG 16-※	1	44.45	51.8

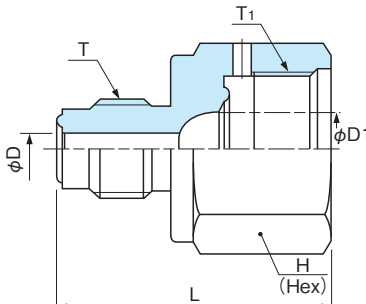
Reduced Adapter	Part No	Size of VTF	Size of VTF	$\phi D$	$\phi D_1$	H Hex. size	L
	VTSS 2-4-※	1/8	1/4	2.3	—	19	30.2
	VTSS 4-2-※	1/4	1/8	4.35	3.3	15.88	29.1
	VTSS 4-4-※	1/4	1/4	4.35	—	19.0	35.0
	VTSS 4-8-※	1/4	1/2	4.35	10.2	26.99	38.5
	VTSS 4-12-※	1/4	3/4	4.35	15.75	38.1	44.8
	VTSS 8-4-※	1/2 (3/8)	1/2	10.2	4.35	23.81	38.2
	VTSS 8-12-※	1/2 (3/8)	3/4	10.2	15.75	38.1	48
	VTSS 12-4-※	3/4	1/4	15.75	4.35	33.34	45
	VTSS 12-8-※	3/4	1/2	15.75	10.2	33.34	48

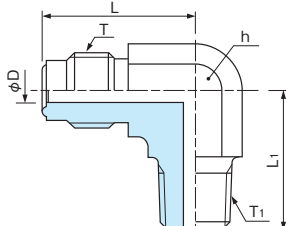
Male Elbow (NPT thread)	Part No	Size of VTF	T <sub>1</sub> NPT thread	$\phi D$	h Width flats	L	L <sub>1</sub>
	VTLN 4-2-※	1/4	1/8	4.35	17.5	28.7	22.4
	VTLN 4-4-※	1/4	1/4	4.35	17.5	28.7	26.9
	VTLN 8-4-※	1/2 (3/8)	1/4	10.2	20.6	33.3	26.9
	VTLN 8-6-※	1/2 (3/8)	3/8	10.2	20.6	33.3	28.2
	VTLN 8-8-※	1/2 (3/8)	1/2	10.2	20.6	33.3	33.3
	VTLN 12-12-※	3/4	3/4	15.75	31.8	46.0	39.7

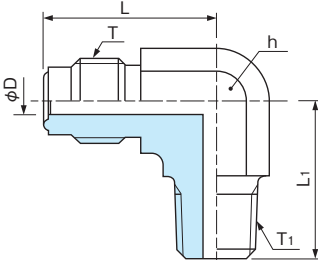
Male Elbow (R thread)	Part No	Size of VTF	T <sub>1</sub> R thread	$\phi D$	h Width flats	L	L <sub>1</sub>
	VTLN 4-R2-※	1/4	1/8	4.35	17.5	28.7	22.4
	VTLN 4-R4-※	1/4	1/4	4.35	17.5	28.7	26.9
	VTLN 4-R6-※	1/4	3/8	4.35	20.6	28.7	28.2
	VTLN 8-R6-※	1/2 (3/8)	3/8	10.2	20.6	33.3	28.2
	VTLN 8-R8-※	1/2 (3/8)	1/2	10.2	20.6	33.3	33.3
	VTLN 12-R4-※	3/4	1/4	15.75	31.8	46	36.7
	VTLN 12-R8-※	3/4	1/2	15.75	31.8	46	39.7
	VTLN 12-R12-※	3/4	3/4	15.75	31.8	46	39.7

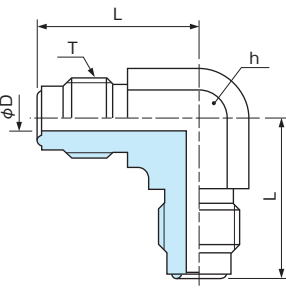

Union Elbow	Part No	Size of VTF	$\phi D$	h Width flats	L
	VTLA 2-※	1/8	2.3	11.11	19.8
	VTLA 4-※	1/4	4.35	17.5	28.7
	VTLA 8-※	1/2 (3/8)	10.2	20.6	33.3
	VTF-LA 2-※	1/8	2.3	11.11	22.6
	VTF-LA 4-※	1/4	4.35	17.5	27.2
	VTF-LA 8-※	1/2 (3/8)	10.2	25.0	36.8
	VTF-LA 12-※	3/4	15.7	34.0	48.8
	VTF-LA 16-※	1	22.1	42.9	50.8

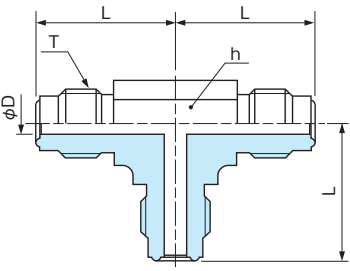
Union Tee	Part No	Size of VTF	$\phi D$	h Width flats	L
	VTTA 2-※	1/8	2.3	11.1	19.8
	VTTA 4-※	1/4	4.35	17.5	28.7
	VTTA 8-※	1/2 (3/8)	10.2	20.6	33.3
	VTF-TA 2-※	1/8	2.3	11	22.6
	VTF-TA 4-※	1/4	4.35	17.5	27.2
	VTF-TA 8-※	1/2 (3/8)	10.2	25.0	36.8
	VTF-TA 12-※	3/4	15.7	34.0	48.8
	VTF-TA 16-※	1	22.1	42.9	50.8

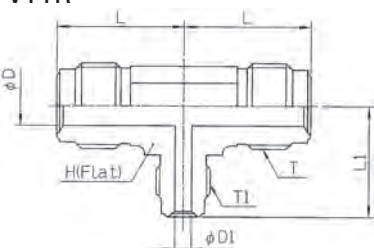
Reducing Tee	Part No	Size of VTF	Size of VTF	$\phi D$	h Width flats	L	L <sub>1</sub>	D <sub>2</sub>
	VTTR8-4-※	1/2 (3/8)	1/4	10.2	20.6	33.3	30	4.35
	VTTR12-4-※	3/4	1/4	15.75	35.0	41.8	34	4.35

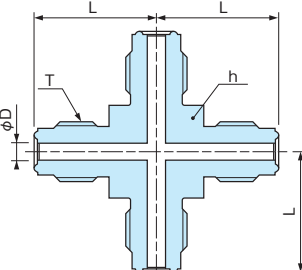
Union Cross	Part No	Size of VTF	$\phi D$	h Width flats	L
	VTXA 2-※	1/8	2.3	11.11	19.8
	VTXA 4-※	1/4	4.35	17.5	28.7
	VTXA 8-※	1/2 (3/8)	10.2	20.6	33.3
	VTF-XA 2-※	1/8	2.3	11.1	22.6
	VTF-XA 4-※	1/4	4.35	17.5	27.2
	VTF-XA 8-※	1/2 (3/8)	10.2	25.0	36.8

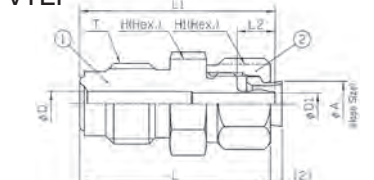
Connector for Resin tube fitting	Part No	Size of VTF	Resin tube fitting	$\phi D$	h Width flats	L	D <sub>1</sub>
			Size				
	VTEP4-6.35×4.35-※	1/4	$\phi 6 \times \phi 4$	4.35	15.88	34.2	3.9

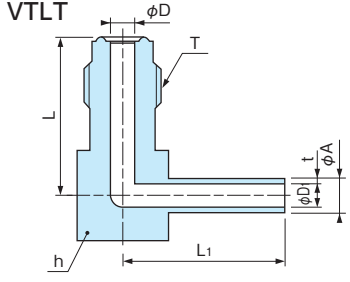
Elbow for Butt Weld	Part No	Size of VTF	Tube		$\phi D$	h Width flats	$\phi D_1$	L	L <sub>1</sub>	$\ell$
			size ( $\phi A$ )	Thickness (t)						
	VTLT 4-4-※	1/4	6.35	1.0	4.35	17.0	4.35	27.2	25.0	16.5
	VTLT 4-4S-※	1/4	6.35	1.0	4.35	17.0	4.35	27.2	14.9	6.4
	VTLT 8-4-※	1/2 (3/8)	6.35	1.0	10.2	25.0	4.35	33.3	33.3	19.0
	VTLT 8-6-※	1/2 (3/8)	9.53	1.0	10.2	25.0	7.5	33.3	33.3	19.0
We also manufacture other dimensions/sizes										

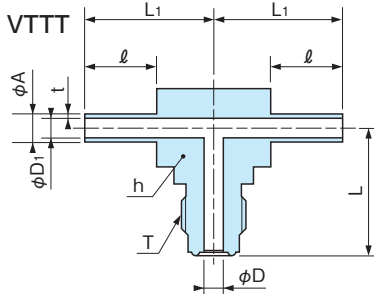
Tee for Butt Weld	Part No	Size of VTF	Tube		$\phi D$	h Width flats	$\phi D_1$	L	L <sub>1</sub>	$\ell$
			size ( $\phi A$ )	Thickness (t)						
	VTTT 4-4-※	1/4	6.35	1.0	4.35	17.0	4.35	27.2	25.0	16.5
	VTTT 6-4-※	1/4	9.53	1.0	4.35	17.0	7.5	27.2	25.0	16.5
	VTTT 4-8-※	1/2 (3/8)	6.35	1.0	7.5	25.0	4.35	33.3	33.3	19.0
	VTTT 6-8-※	1/2 (3/8)	9.53	1.0	7.5	25.0	7.5	33.3	33.3	19.0
We also manufacture other dimensions/sizes										

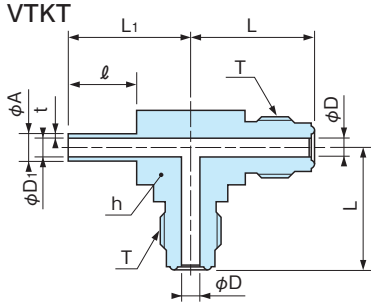
Tee for Butt Weld	Part No	Size of VTF	Tube		$\phi D$	h Width flats	$\phi D_1$	L	L <sub>1</sub>	$\ell$
			size ( $\phi A$ )	Thickness (t)						
	VTKT 4-4-4-※	1/4	6.35	1.0	4.35	17.0	4.35	27.2	25.0	16.5
	VTKT 4-4S-4-※	1/4	6.35	1.0	4.35	17.0	4.35	27.2	15.0	6.35
We also manufacture other dimensions/sizes										

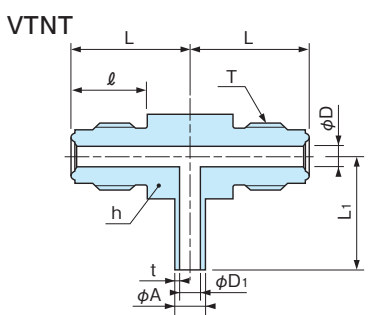
Bulkhead Tee for Butt Weld	Part No	Size of VTF	Tube		$\phi D$	h Width flats	$\phi D_1$	L	L <sub>1</sub>	$\ell$
			size ( $\phi A$ )	Thickness (t)						
	VTNT 4-4-※	1/4	6.35	1.0	4.35	17.0	4.35	27.2	25.0	16.5
We also manufacture other dimensions/sizes										

Welded Connector (R thread)	Part No	Size of VTF	T R thread	$\phi D$	H Hex. size	H <sub>1</sub> Hex. size	L
WVTCT 4-R4-※	1/4	1/4	4.35	19	14.29	45.5	
WVTCT 4-R6-※	1/4	3/8	4.35	19	19	46	
WVTCT 8-R4-※	1/2 (3/8)	1/4	4.35	26.99	14.29	45.5	
WVTCT 8-R6-※	1/2 (3/8)	3/8	7.5	26.99	19	50.2	
WVTCT 8-R8-※	1/2 (3/8)	1/2	10.2	26.99	22.23	53.2	
WVTCT 12-R12-※	3/4	3/4	15.75	38.1	30	96.3	

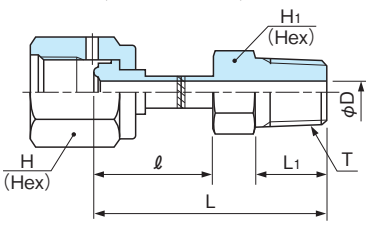
Welded Connector (NPT thread)	Part No	Size of VTF	T NPT thread	$\phi D$	H Hex. size	H <sub>1</sub> Hex. size	L
<b>WVTCT (NPT thread)</b> 	WVTCT 4-R2-※	1/4	1/8	4.35	19	12	39.4
	WVTCT 4-R4-※	1/4	1/4	4.35	19	14.29	45.5
	WVTCT 4-R6-※	1/4	3/8	4.35	19	19	46
	WVTCT 8-R4-※	1/2 (3/8)	1/4	4.35	26.99	14.29	45.5
	WVTCT 8-R6-※	1/2 (3/8)	3/8	7.5	26.99	19	50.2
	WVTCT 8-R8-※	1/2 (3/8)	1/2	10.2	26.99	22.23	53.2
	WVTCT 12-R12-※	3/4	3/4	15.75	38.1	30	96.3

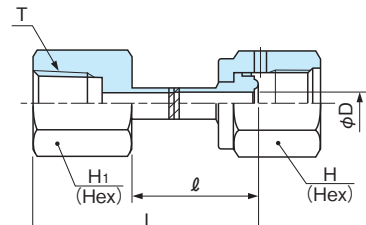
Welded Connector (Rc thread)	Part No	Size of VTF	T RC thread	$\phi D$	H Hex. size	H <sub>1</sub> Hex. size	L
<b>WVTSA (Rc thread)</b> 	WVTSA 4-R2-※	1/4	1/8	4.35	19	14	42.5
	WVTSA 4-R4-※	1/4	1/4	4.35	19	19	45.5
	WVTSA 4-R6-※	1/4	3/8	4.35	19	22.23	49.8
	WVTSA 8-R4-※	1/2 (3/8)	1/4	10.2	26.99	19	45.5
	WVTSA 8-R6-※	1/2 (3/8)	3/8	10.2	26.99	22.23	49.8
	WVTSA 8-R8-※	1/2 (3/8)	1/2	10.2	26.99	26.99	55.4
	WVTSA 12-R12-※	3/4	3/4	15.75	38.1	33.34	85
	WVTSA 16-R16-※	1	1	22.1	44.45	41.28	98

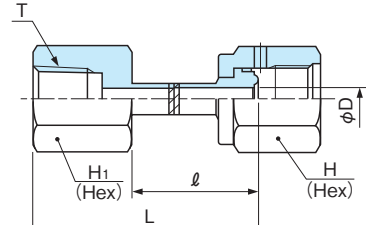
Welded Connector (NPT thread)	Part No	Size of VTF	T NPT thread	$\phi D$	H Hex. size	H <sub>1</sub> Hex. size	L
<b>WVTSA (NPT thread)</b> 	WVTSA 4-2-※	1/4	1/8	4.35	19	14	42.5
	WVTSA 4-4-※	1/4	1/4	4.35	19	19	45.5
	WVTSA 4-6-※	1/4	3/8	4.35	19	22.23	49.8
	WVTSA 8-4-※	1/2 (3/8)	1/4	10.2	26.99	19	45.5
	WVTSA 8-6-※	1/2 (3/8)	3/8	10.2	26.99	22.23	49.8
	WVTSA 8-8-※	1/2 (3/8)	1/2	10.2	26.99	20.99	55.4
	WVTSA 12-12-※	3/4	3/4	15.75	38.1	33.34	85
	WVTSA 16-16-※	1	1	22.1	44.45	41.28	98

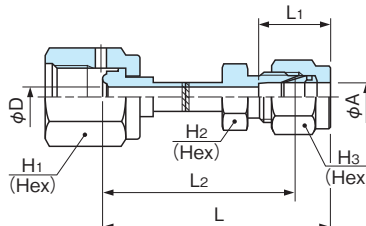
Welded BI-LOK Fitting Connector	Part No	Size of VTF	Size of BI-LOK ( $\phi A$ )	$\phi D$	H <sub>1</sub> Hex. size	H <sub>2</sub> Hex. size	H <sub>3</sub> Hex. size	L <sub>1</sub>	L <sub>2</sub>	L
<b>WVTUB</b> 	WVTUB 4-4-※	1/4	6.35	4.35	19.05	12.7	14.29	15.4	41.8	49.3
	WVTUB 4-6-※	1/4	9.53	4.35	19.05	15.88	17.46	17	42.5	50
	WVTUB 4-8-※	1/4	12.7	4.35	19.05	20.64	22.23	23	43.5	53.8
	WVTUB 8-4-※	1/2 (3/8)	6.35	10.2	26.99	15.88	14.29	15.4	43.1	50.6
	WVTUB 8-6-※	1/2 (3/8)	9.53	10.2	26.99	15.88	17.46	17	45.0	52.5
	WVTUB 8-8-※	1/2 (3/8)	12.7	10.2	26.99	20.64	22.22	23	47.0	57.3
	WVTUB 12-6-※	3/4	9.53	15.75	38.1	20.64	17.46	17	68.6	76.1
	WVTUB 12-8-※	3/4	12.7	15.75	38.1	20.64	22.23	23	68.6	78.9
	WVTUB 12-12-※	3/4	19.05	15.75	38.1	26.99	28.58	24.6	88.9	99.2
	WVTUB 16-8-※	1	12.7	22.1	44.45	26.99	22.23	23	84.6	94.9
	WVTUB 16-16-※	1	25.4	22.1	44.45	34.93	38.1	31.6	87	100.0

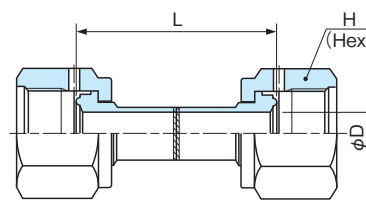
Closed Coupling	Part No	Size of VTF	$\phi D$	H Hex. size	L
<b>WVTGE</b> 	WVTGE 4-4-※	1/4	4.35	19	43.4
	WVTGE 8-8-※	1/2 (3/8)	10.2	26.99	47.0
	WVTGE 12-12-※	3/4	15.75	38.1	70.0

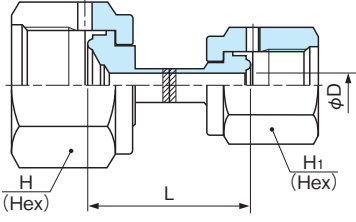
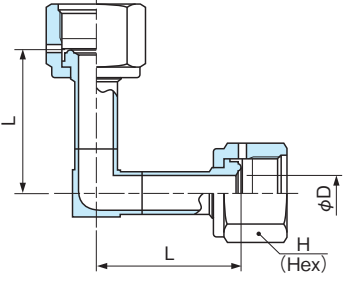
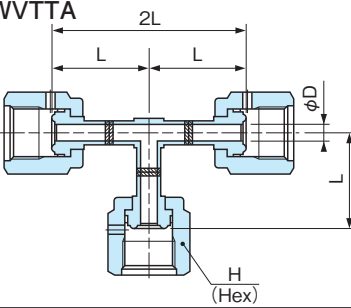
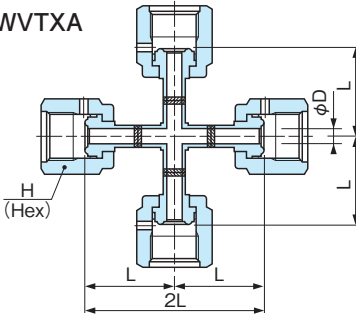
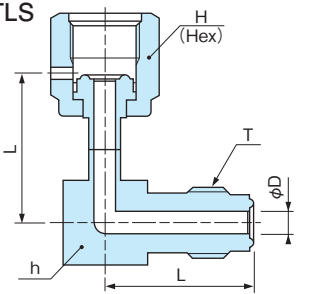
Reducing Closed Coupling	Part No	Size of VTF	Size of VTF	$\phi D$	H Hex. size	H <sub>1</sub> Hex. size	L		
<b>WVTRGE</b> 	WVTRGE 8-4-※	1/2	1/4	4.35	26.99	19	30.4		
Welded Female Elbow	Part No	Size of VTF	$\phi D$	H Hex. size	L				
<b>WVTLA</b> 	WVTLA 4-4-※	1/4	4.35	19	25.4				
	WVTLA 8-8-※	1/2 (3/8)	10.2	26.99	28.6				
Welded Female Tee	Part No	Size of VTF	$\phi D$	H Hex. size	L	2L			
<b>WVTTA</b> 	WVTTA 4-4-※	1/4	4.35	19	25.4	50.8			
	WVTTA 8-8-※	1/2 (3/8)	10.2	26.99	28.3	56.6			
Welded Female Cross	Part No	Size of VTF	$\phi D$	H Hex. size	L	2L			
<b>WVTXA</b> 	WVTXA 4-4-※	1/4	4.35	19	25.4	50.8			
	WVTXA 8-8-※	1/2 (3/8)	10.2	26.99	28.3	56.6			
Welded Male-Female Elbow	Part No	Size of VTF	T unified thread	$\phi D$	H Hex. size	h Width flats	L		
<b>WVTLS</b> 	WVTLS 4-4-※	1/4	9/16-18	4.35	19.05	17.0	30.0		

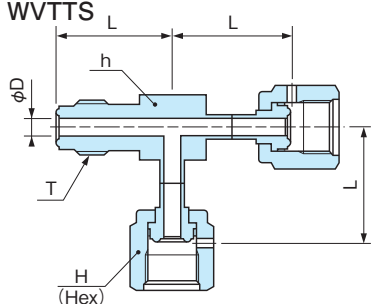
Welded Male-Female Tee	Part No	Size of VTF	$\phi D$	H Hex. size	h Width flats	L
	WVTTS 4-4-※	1/4	4.35	19.05	17.0	30.0

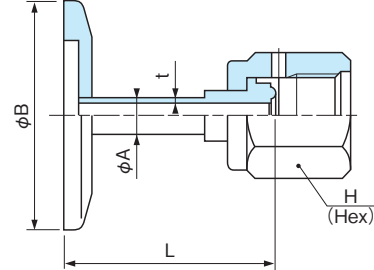
Female Nut Adapter with NW Flange Welded	Part No	Size of VTF	Size of NW Flange ( $\phi B$ )	t	H Hex. size	L
	VTF - NW16 - 4VF - ※	1/4	30	1.0	19.05	31.0
	VTF - NW16 - 8VF - ※	1/2 (3/8)	30	1.24	26.99	31.5
	VTF - NW25 - 4VF - ※	1/4	40	1.0	19.05	31.0
	VTF - NW25 - 8VF - ※	1/2 (3/8)	40	1.24	26.99	31.5
	VTF - NW25 - 12VF - ※	3/4	40	1.65	38.1	38.0
	VTF - NW40 - 4VF - ※	1/4	55	1.0	19.05	31.0
	VTF - NW40 - 8VF - ※	1/2 (3/8)	55	1.24	26.99	31.5
	VTF - NW40 - 12VF - ※	3/4	55	1.65	38.1	38.0
	VTF - NW50 - 4VF - ※	1/4	75	1.0	19.05	31.0
	VTF - NW50 - 8VF - ※	1/2 (3/8)	75	1.24	26.99	31.5

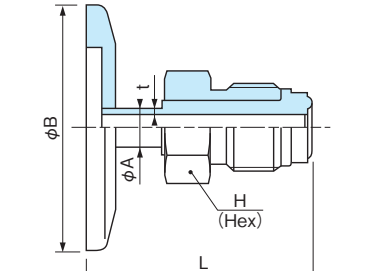
Male Nut Adapter with NW Flange Welded	Part No	Size of VTF	Size of NW Flange ( $\phi B$ )	t	H Hex. size	L
	VTF - NW16 - 4VM - ※	1/4	30	1.0	15.88	46.2
	VTF - NW16 - 8VM - ※	1/2 (3/8)	30	1.24	23.81	48.5
	VTF - NW25 - 4VM - ※	1/4	40	1.0	15.88	46.2
	VTF - NW25 - 8VM - ※	1/2 (3/8)	40	1.24	23.81	48.5
	VTF - NW25 - 12VM - ※	3/4	40	1.65	33.34	54.6
	VTF - NW40 - 4VM - ※	1/4	55	1.0	15.88	46.2
	VTF - NW40 - 8VM - ※	1/2 (3/8)	55	1.24	23.81	48.5
	VTF - NW40 - 12VM - ※	3/4	55	1.65	33.34	54.6
	VTF - NW50 - 4VM - ※	1/4	75	1.0	15.88	46.2
	VTF - NW50 - 8VM - ※	1/2 (3/8)	75	1.24	23.81	48.5

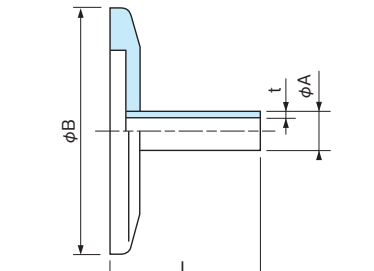
Tube-end Adapter with NW Flange Welded	Part No	Size of NW Flange ( $\phi B$ )	$\phi A$	t	L
	VTF - NW16 - 4TW - ※	30	6.35	1.0	100
	VTF - NW16 - 6TW - ※	30	9.53	1.0	100
	VTF - NW25 - 4TW - ※	40	6.35	1.0	100
	VTF - NW25 - 6TW - ※	40	9.53	1.0	100
	VTF - NW40 - 4TW - ※	55	6.35	1.0	100
	VTF - NW40 - 6TW - ※	55	9.53	1.0	100
	VTF - NW50 - 4TW - ※	75	6.35	1.0	100
	VTF - NW50 - 6TW - ※	75	9.53	1.0	100

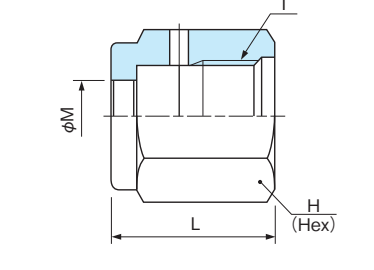
Female Nut	Part No	Size of VTF	$\phi M$	H Hex. size	L
	VTNA 2	1/8	5.15	11.1	13.5
	VTNA 4	1/4	9.1	19	20.6
	VTNA 8	1/2 (3/8)	15.5	26.99	22.4
	VTNA 12	3/4	22.6	38.1	28.4
	VTNA 16	1	30.5	44.45	34.0

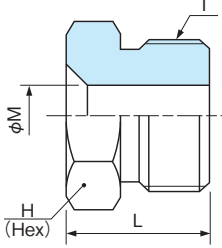
Male Nut	Part No	Size of VTF	$\phi M$	H Hex. size	L
	VTNB 2	1/8	5.15	9.53	12.7
	VTNB 4	1/4	8.9	15.88	18.3
	VTNB 8	1/2 (3/8)	15.2	23.81	20.6
	VTNB 12	3/4	22.4	33.34	25.4
	VTNB 16	1	30.5	41.27	30.2

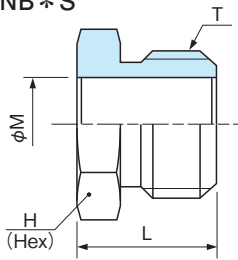
Short Male Nut	Part No	Size of VTF	$\phi M$	H Hex. size	L
	VTNB 4S	1/4	8.9	15.88	13.7
	VTNB 8S	1/2 (3/8)	15.2	23.81	15.6

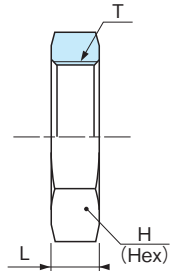
Lock Nut	Part No	Size of VTF	T unified thread	H Hex. size	L
	VTNN 2	1/8	5/16-24	11.11	6.0
	VTNN 4	1/4	9/16-18	19	6.0
	VTNN 8	1/2 (3/8)	7/8-14	26.99	8.0
	VTNN 12	3/4	1 · 1/4-18	38.1	10.0
	VTNN 16	1	1 · 1/2-20	47.63	12.5

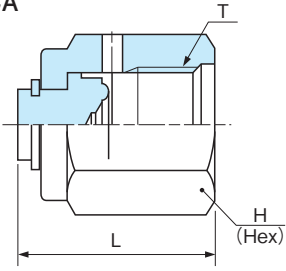
Cap	Part No	Size of VTF	H Hex. size	L
	VTCA 2	1/8	11.11	15.7
	VTCA 4	1/4	19	23.5
	VTCA 8	1/2 (3/8)	26.99	25.9
	VTCA 12	3/4	38.1	31.2
	VTCA 16	1	44.45	39.2

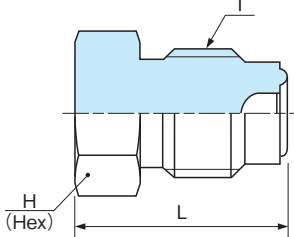
Plug	Part No	Size of VTF	H Hex. size	L
	VTBA 2	1/8	9.53	17.3
	VTBA 4	1/4	15.88	23.1
	VTBA 8	1/2 (3/8)	23.81	27.4
	VTBA 12	3/4	33.34	35.8
	VTBA 16	1	41.27	38.6

## How to Order

When placing an order, add the "Material code" to the end of the part number.

\*Silver plating is not available for these components.

Material	Symbol	Example
Nickel	Ni	VTGP 4Ni
		VTGR 4Ni
SUS316L W melt	W	VTGP 4W
		VTGR 4W

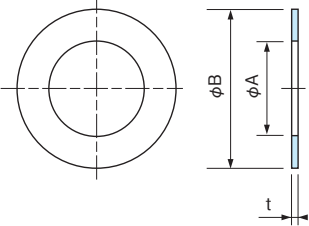
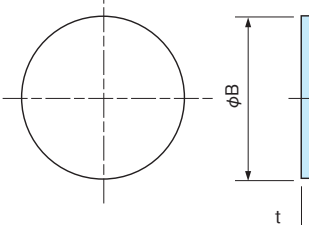
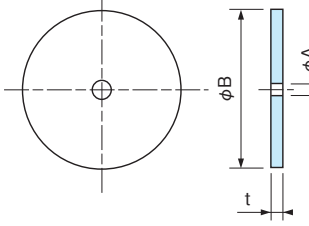
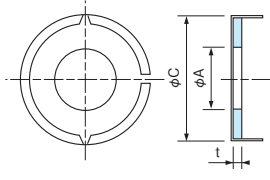
(mm)					
Gasket	Part No	Size of VTF	$\phi A$	$\phi B$	t
<b>VTGP, VTGP * RN</b> 	VTGP 2-※	1/8	2.3	6.4	0.5
	VTGP 4-※	1/4	5.6	11.3	0.8
	VTGP 8-※	1/2 (3/8)	11.2	18.55	0.8
	VTGP 12-※	3/4	16.8	27.5	0.8
	VTGP 16-※	1	22.35	34.03	0.8
	VTGP 4RN-※	1/4	5.6	11.9	0.8
	VTGP 8RN-※	1/2 (3/8)	11.2	19.8	0.8
	VTGP 12RN-※	3/4	16.8	29.0	0.8
Note: The VTGP2, VTGP16. and RN types do not use a gasket holder					
Blind Gasket	Part No	Size of VTF	$\phi B$	t	
<b>VTBP</b> 	VTBP 2-※	1/8	6.4	0.5	
	VTBP 4-※	1/4	11.3	0.8	
	VTBP 8-※	1/2 (3/8)	18.55	0.8	
	VTBP 12-※	3/4	27.5	0.8	
	VTBP 16-※	1	34.03	0.8	
4, 8, and 12 can be used with holder.					
Orifice Gasket	Part No	Size of VTF	* $\phi A$	$\phi B$	t
<b>VTOP</b> 	VTOP 4※-01	1/4	0.1	11.3	0.8
	VTOP 4※-10	1/4	1.0	11.3	0.8
	VTOP 8※-01	1/2 (3/8)	0.1	18.55	0.8
	VTOP 8※-10	1/2 (3/8)	1.0	18.55	0.8
* We offer orifices from $\phi 0.1\text{mm}$ to $\phi 1.0\text{mm}$ in increments of 0.05mm (Ex.VTOP 4Ni-015)					
Gasket with Holder	Part No	Size of VTF	$\phi A$	$\phi C$	t
<b>VTGR = VTRT + VTGP</b> <small>Holder type</small> 	VTGR 4-※	1/4	5.6	11.9	0.8
	VTGR 8-※	1/2 (3/8)	11.2	19.15	0.8
	VTGR 12-※	3/4	16.8	28.1	0.8
* Part No.of only holder is VTRT4, VTRT8, VTRT12.					

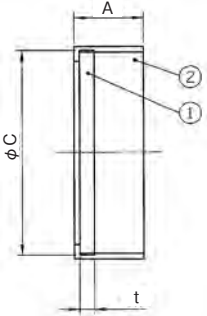
VTBR	Part No	Size of VTF	A	C	t
	VTBR4-※	1/4	5.6	11.9	0.8
	VTBR8-※	1/2 (3/8)	11.2	19.15	0.8

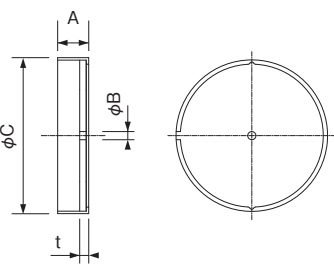
VTOR	Part No	Size of VTF	A	φ B	φ C	t
	VTOR4※-01	1/4	5.6	0.1	11.9	0.8
	VTOR8※-01	1/2 (3/8)	11.2	0.1	19.15	0.8
* We offer orifices from φ0.1mm to φ1.0mm in increments of 0.05mm (Ex.VTOR 4Ni-015)						

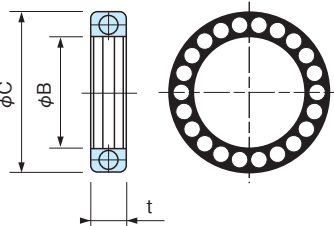
Thrust Bearing	Part No	Size of VTF	φ B	φ C	t
	VTJR 4	1/4	9.0	12.7	2.8
	VTJR 8	1/2 (3/8)	15.3	20.3	3.5

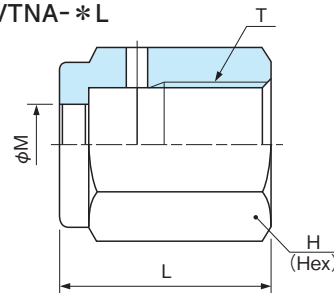
Female Nut for Thrust Bearing	Part No	Size of VTF	φ M	H Hex. size	L
	VTNA-4L	1/4	9.1	19	23.3
	VTNA-8L	1/2 (3/8)	15.5	26.99	26.0

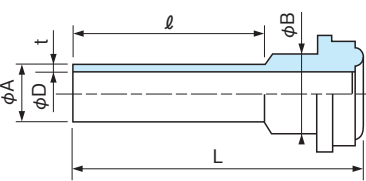
Long Gland for Thrust Bearing Female Nut	Part No	Size of VTF	Tube		φ D	φ B	L	ℓ
			size (φ A)	Thickness(t)				
	VTF-GE4-28L-※	1/4	6.35	1.0	4.35	8.8	27.9	16.25
	VTF-GE8-6-28L-※	1/2 (3/8)	9.53	1.0	7.5	15.1	28.5	14.6
	VTF-GE8-28L-※	1/2 (3/8)	12.7	1.24	10.2	15.1	28.5	15.55

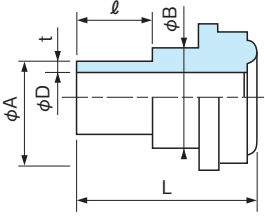

Short Gland for Thrust Bearing Female Nut	Part No	Size of VTF	Tube		$\phi D$	$\phi B$	L	$\ell$
			size ( $\phi A$ )	Thickness (t)				
	VTF-GN4-18L-※	1/4	6.35	1.0	4.35	8.8	18.2	6.35
	VTF-GN8-19L-※	1/2 (3/8)	12.7	1.24	10.2	15.1	18.8	6.35

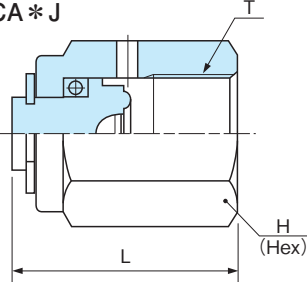
Thrust Bearing Cap	Part No	Size of VTF	H Hex. size	L
	VTCA 4J	1/4	19	26.4
	VTCA 8J	1/2 (3/8)	26.99	29.5

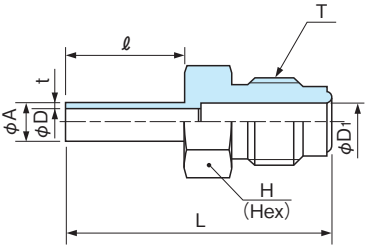
Compact Coupling	Part No	Size of VTF	Tube		$\phi D_1$	$\phi D$	H Hex. size	L	$\ell$
			size ( $\phi A$ )	Thickness (t)					
	VTGF 4-4-※	1/4	6.35	1.0	6.0	4.35	15.88	42.7	19.05
	VTGF 4-6-※	1/4	9.53	1.0	6.0	7.5	15.88	42.7	19.05
	VTGF 4-8-※	1/4	12.7	1.24	6.0	10.2	15.88	42.7	19.05
	VTGF 8-12-※	1/2 (3/8)	19.05	1.65	13.0	15.75	23.81	46.0	19.05

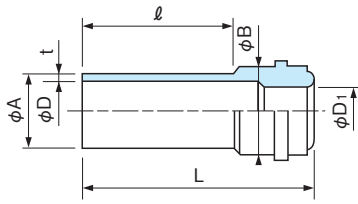
Gland for Compact Female Nut	Part No	Size of VTF	Tube		$\phi D_1$	$\phi D$	$\phi B$	L	$\ell$
			size ( $\phi A$ )	Thickness (t)					
	VTGH 4-6-※	1/4	9.53	1.0	6.0	7.5	11.2	29.0	19.05
	VTF-GH4-6-15A-※	1/4	9.53	1.0	6.0	7.5	11.2	15.2	6.35
	VTF-GH4-6-30A-※	1/4	9.53	1.0	6.0	7.5	11.2	30.2	19.05
	VTF-GH4-6-33A-※	1/4	9.53	1.0	6.0	7.5	11.2	33.3	19.05

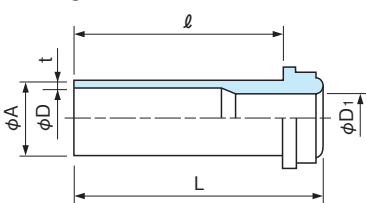
Gland for Compact Male Nut	Part No	Size of VTF	Tube		$\phi D_1$	$\phi D$	L	$\ell$
			size ( $\phi A$ )	Thickness (t)				
	VTF-GK4-6-16B	1/4	9.53	1.0	6.0	7.5	15.5	10.7
	VTF-GK4-6-29B	1/4	9.53	1.0	6.0	7.5	28.7	23.9
	VTF-GK4-6-31B	1/4	9.53	1.0	6.0	7.5	31.0	26.2
	VTF-GK4-6-43B	1/4	9.53	1.0	6.0	7.5	43.2	38.4

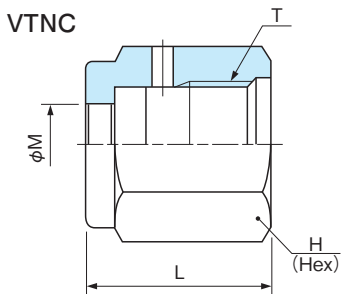
Compact Female Nut	Part No	Size of VTF	$\phi M$	H Hex. size	L
<b>VTNC</b> 	VTNC 4	1/4	11.5	19.05	20.6

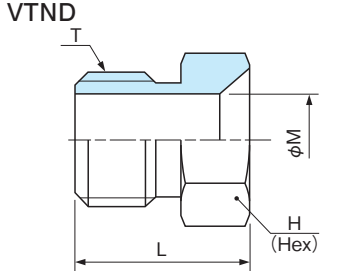
Compact Male Nut	Part No	Size of VTF	$\phi M$	H Hex. size	L
<b>VTND</b> 	VTND 4	1/4	9.7	15.88	18.2

## ◆ Assembly Procedure

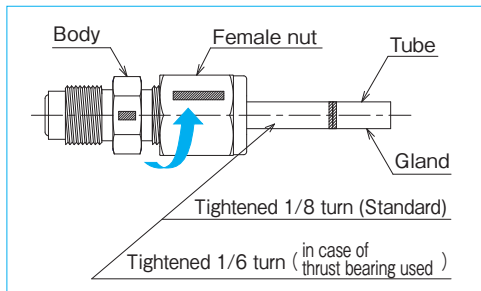
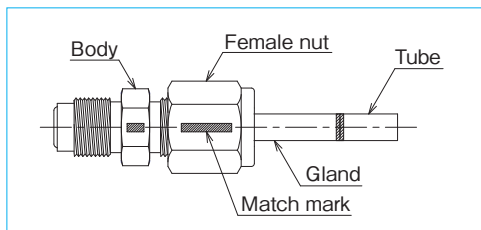
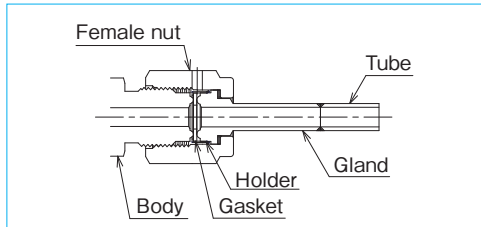
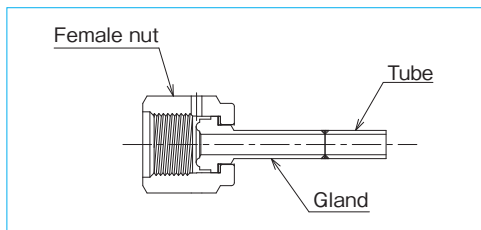

1. Attach the female nut to the gland.
2. Remove the protection cap from the gland.  
Pay attention not to damage bead face.
3. Weld gland and tube.
4. Affix the gasket with the holder to the gland that was welded to the tube.
5. Remove the bead protection cap on the mating side such as the connector body.
6. Fix tightly fitting body or male nut, and finger tighten the female nut until the gasket contacts the mating bead surface.
7. At this position, draw matching marks on fitting body and female nut with ink.
8. Hold the body tightly with back up wrench. Then tighten the female nut by 1/8 turn from the matching marks.  
In case of using a thrust bearing, however, tighten by 1/6 turn.

## ◆ Remaking Procedure

### ① When no replacing both the Gasket and the Thrust washer

In remaking, it will be sufficient to only slightly additionally tighten (5~10°) the female nut with the spanner. Note that the finger tight position in the remake will not be same as the finger tight position before disassembly. The same applies to the fixtures that do not use a thrust washer.

### ② When replacing only the Gasket

After finger tighten, put new match marks on the body and the nut, then tighten 1/8 turn (45°) with spanner. The difference of rotation from above par.9 will depend upon whether there has been initial deformation of the washer.

**Note: As stated above, nut rotation for remaking is different when replace only gasket.**

**Replacing together with the thrust washer is recommended from tightening control.**

## ◆ Replacement of Gasket

Gasket can be repeatedly used several times (4 ~ 5 times). However, in the case of used for severe special gas, it is recommended that the gasket is replaced with a new one at each disassembly.

## ◆ Handle With Care

① For protection of the bead, keep on the protection cap during storage, transportation, and weld preparation.

② All the parts are packed under clean room atmosphere after precisely cleaned.

In application where fat and oil present problems, jigs and tools have to be degreased and washed clean prior to use. Also workers had better wear the dust-proof gloves not to touch the parts with bare hand.

## Related Products

### Tube Cutter



This machine cuts the stainless tube precisely without contamination the clean atmosphere. As no outer burr is generated, it's ready to automatic weld just after cutting without end surface finish.

### AWF



This type of fitting is for Ultra high purity gas services of semiconductor, liquid crystal manufacturing facilities, etc.. Clean stainless material which is vacuum treated is used and vacuum packaged in double in a clean room.

### Diaphragm Valves



Outer sealing with metal diaphragm realize high airtightness, high durability and dead space free. Suitable for high purity fluid.

### Bellows Valves



Outer sealing with metal bellows realize higher airtightness. As the leakage from the gland can be avoided, this type is ideal for such a poisonous gas service that is required higher leak-proof performance.

**⚠ WARNING** If you don't select and handle fittings, valves and related accessories in an adequate manner, it may damage human beings and applicable systems. Within the responsibility and authorization of users and piping designers, fittings, valves and related accessories shall be adequately selected, assembled, used and maintained based on the applicable conditions and product conformity to the system to be applied. Please read carefully our operation manual and feel free to contact with Ihara if you have any question or request.



ISO9001, ISO14001 Certified Office  
Certified office for high-pressure gas facility testing and manufacturing,  
certified office for N valves and N-II fittings

**IHARA SCIENCE CORPORATION**

### Headquarters/Sales Offices

#### Headquarters

#### East Japan Sales Office

11-3 Takanawa 3-chome Minato-ku,  
Tokyo 108-0074 Japan  
TEL: 03-6721-6981 FAX: 03-6721-6991

#### Tohoku Sales Office

5600-3, Higashineko, Oaza, Higashine city,  
Yamagata prefecture 999-3701  
TEL: 0237-43-7802 FAX: 0237-43-7803

#### Chubu Sales Office

Tsukasa Building, 3-14-19, Chiyoda, Naka ward, Nagoya city, Aichi  
prefecture 460-0012  
TEL: 052-323-2627 FAX: 052-323-2630

#### Kansai Sales Office

7F, GL Osaka Building, 4-1-18, Tenma, Kita ward Osaka city, Osaka  
prefecture 530-0043  
TEL: 06-6358-9255 FAX: 06-6358-9260

#### Kyushu Sales Office

103, Maison de Sophie, 1-1-8, Onoue, Kumamoto city, Kumamoto  
prefecture 862-0913  
TEL: 096-386-5353 FAX: 096-386-5354

### Group Companies

#### Yamagata-Ihara Corporation

5600-3, Higashineko, Oaza, Higashine city,  
Yamagata prefecture 999-3701  
TEL: +81-237-43-5501 FAX: +81-237-43-5504

#### IHARA SCIENCE TAIWAN Co.,Ltd

No.79, Mingyi St., West Dist.,  
Taichung City 403, Taiwan (R.O.C.)  
TEL: +886-4-2319-1116 FAX: +886-4-2319-1126

#### SUZHOU IHARA SCIENCE Co.,Ltd.

SHANGHAI OFFICE  
UnitJ-11F, Huamin Empire Plaza, No.728, YanAn Road(W),  
Shanghai 200050, R.P.China  
TEL: +86-21-5239-9884 FAX: +86-21-5283-3811

#### IHARA KOREA Co.,Ltd

Digital Empire II103-905, Sinwon-ro 88, Yeongtong-Gu, Suwon-Si  
Gyeonggi-Do, 443-734, South Korea  
TEL: +82-31-695-6800 FAX: +82-31-695-6808

#### IHARA SCIENCE USA CORPORATION

1915 Peters Road, Suite 103 Irving, Texas 75061  
TEL: +1-469-586-4671 FAX: +1-469-586-4723

■ URL : <http://www.ihara-sc.co.jp>

■ The contents of this catalog are subject to change without notice due to improvement of products or other reasons.